

Kindergarten
We Believe
Teacher Manual



Havadamk • Համառոտաբ

By order of
Archbishop Khajag Barsamian, Primate

A Publication of the Department of Christian Education
Diocese of the Armenian Church of America (Eastern)
©2006, Revised Edition 2014

Cover: Siran Kaprielian Pirani
Design: Armen Edgarian
Project Director/Editor: Elise Antreassian

Kindergarten • Teacher Manual

We Believe

Havadamk • Հավատամք

Rose Aznavorian

Introduction to the We Believe Sunday School Curriculum

The goal of the new curriculum series is *“to bring the learner into a living relationship with Jesus Christ, within the Church - the Body of Christ - through the Holy Tradition of the Armenian Church.”* Overall, the curriculum will help students explore four fundamental questions:

1. Who is God (Father, Son, Holy Spirit)?
2. How do we come to know him through the familiar and life-giving Tradition of the Armenian Church and through her story?
3. How are our lives transformed by that knowledge?
4. How do we live in Christian community with that knowledge?

The Armenian Church is fortunate in that its faithful are active communicants in the life of the Church from the moment they are baptized as infants. They are able to participate fully in experiential, formative faith. Not only the curriculum and the Sunday School teacher, but also parents, pastors, and the entire community support the process of the learner’s transformation from “knowing about” Christ to true discipleship.

Table of Contents

| | |
|--|----|
| Introduction to the Kindergarten Curriculum | 6 |
| 1. It's a Beautiful World!..... | 9 |
| 2. Come to My Garden..... | 11 |
| 3. Bless This Table..... | 13 |
| 4. God's Amazing Zoo..... | 14 |
| 5. God Made You and Me | 15 |
| 6. God is Love | 17 |
| 7. Noah and a New World..... | 18 |
| 8. Mary the Mother of Jesus | 20 |
| 9. Jesus is the Light of the World..... | 21 |
| 10. A Holy Family | 22 |
| 11. This is My Son..... | 24 |
| 12. Jesus Loves Us..... | 26 |
| 13. We Prepare for Christmas | 27 |
| 14. Jesus is Born!..... | 29 |
| 15. Jesus Called the Disciples..... | 30 |
| 16. Jesus Taught Us How to Live..... | 32 |
| 17. Jesus Taught Us How to Pray | 33 |
| 18. Jesus Taught Us Who He Was..... | 34 |
| 19. Jesus Made People Feel Better | 35 |
| 20. Jesus Taught Us How to be Together | 37 |
| 21. Jesus Taught Us to Share our Faith | 38 |
| 22. We Join the Church with Baptism..... | 39 |
| 23. We Grow in Faith Together..... | 41 |
| 24. We Remember Jesus on Sunday | 42 |
| 25. We Honor Jesus in Church with Words and Actions..... | 43 |
| 26. The Cross is a Special Sign..... | 44 |
| 27. How the Armenians Became a Christian People..... | 46 |
| 28. The People of God Celebrate | 47 |

Introduction to the Kindergarten Curriculum

If you have any experience with kindergarteners, you already know you're in for a wonderful year. Your students will teach *you* even more than you teach them. Their wonder, curiosity and openness are the perfect qualities to help everyone grow closer to our Lord.

Although the Teacher Manual is easy to use and self-explanatory, the following are helpful notes on its use.

Jesus: Bible Stories for Children

The read-aloud storybook that accompanies Kindergarten and will be used again in Grade One is designed to give children a simple overview of the life of our Lord. It is not meant to match the day's lesson or theme. The story of Christmas, for example, is found in the first two stories and will be read in September! Do not worry. Story time will be at the very end of the lesson and is meant to be a separate time to read and talk about Jesus through the chronological events of his life. However, there are stories on his teachings and miracles that you can rearrange to coincide with your lesson.

In Kindergarten, the teacher will read to the children from the *Jesus* reader, so it is recommended that a copy for each teacher be purchased. Then in First Grade, children will each have their own copy to eventually take home.

Order of lessons

The wonderful thing about the *We Believe* Kindergarten student text is that it's not a text! It's a series of independent newsletter-style lessons that can be easily shifted to accommodate holidays or other special considerations. Although they are numbered, feel free to switch their order. The Teacher Manual procedure in each lesson will assume you have distributed the day's newsletter lesson.

Reading level

Kindergarteners are not yet reading at the level used in the student text. Since the lessons are richly illustrated with photos and drawings, there is much to engage the children's interest. The text is brief and designed to be read aloud by the teacher and parents. Short sentences and phrases can be read by most of the students.

Bibles

Always have at the display table a Children's Bible or storybook; having more than one would be ideal. Although they may only occasionally be used, their presence is an important witness to the Bible as a special book.

Timing

Lessons are designed to last 60 minutes. If your Sunday morning program runs longer, we encourage you to augment your 60-minute class with church attendance, assemblies, singing, or other worship or learning experiences rather than lengthen class time.

Also note that timing is approximate, designed simply to give you an idea of how much time to spend on each lesson component. You can make alternate timing decisions.

Display Table

The purpose of the display table is to pique the children's interest and to give a hint of what is to come in the lesson. A list of objects will be suggested for each lesson, but we hope you will revise this list as you wish. Encourage the children to look at and touch the objects before the formal lesson begins. Place a Children's Bible on the table, open to the weekly passage to be read in *God's Word to Us*. While a magnifying glass is only

mentioned in the first lesson, it would be helpful to have some on hand every Sunday (non-breakable plastic magnifying sheets or children's magnifiers should be used). Some items for the display table are harder to get than others. But it's worth the effort! And once you have a full display for a lesson, it is a permanent resource for years to come. Laminate magazine pictures; store display items in a large sealable baggie and identify by lesson.

IMPORTANT: Never leave children alone at the display. You or an assistant should always supervise the table until the lesson begins.

Welcoming the children

Unfortunately, Sunday School children filter into class slowly until everyone has finally arrived. Don't waste time waiting for that moment! Use the time for warm hellos and catching up, as well as time at the display table talking about the objects and preparing the children for today's lesson.

Opening prayer

While the children cannot read, the brief written opening prayer is for classroom as well as at-home use. Invite children to contribute thoughts for prayer.

Story Corner

It's a luxury for some schools to have a special spot in the Kindergarten classroom designated for story telling. The K curriculum begins with a story about everyday life and ends with a story about *Jesus'* life. Ideally, this might be a corner where children can sit on a nice warm rug and the teacher reads them stories, both from their lesson and then from *Jesus*.

This "story corner" can be a real asset, however. It allows children the movement required to keep them from getting bored and restless. It can be a place where you can set up a felt board to develop the story further and allow children more participation. It can also make story time extra special. See if you can't arrange your rooms in such a way that the youngsters get some extra space.

Flannel boards and story pieces, by the way, can be purchased online or from Christian supply stores.

Snack time

Every Sunday, kindergarteners have a break for snack. It's not because they're ravenously hungry, but breaking bread together is a beautiful Christian activity that will involve prayer, service, and mutual care.

Snack time can be arranged as you wish and as is convenient for the school: parents can contribute towards it or the school can provide it; but it's best if it's a family-style event and not individual brown bags from home. This way the pouring of juice and the sharing of a plate of cookies can be a true 'community' event. Of course, prayer, set-up, and clean-up are obligatory for all. On especially busy days or during lessons that involve outdoor activities or church attendance at specific times, snack will be brief or can be dispensed with altogether.

Crafts

It is always tempting for teachers to disregard crafts – they can entail too much time, mess, and preparation. But they are an extremely valuable component of the K classroom. Make sure you have an assistant for those crafts that entail cutting, folding, glitter, etc. and look ahead to assemble necessary supplies well in advance of the lesson. In lesson 27, for example, you need a quart milk container for each child, so give yourself enough time to collect them.

Family Page

Every lesson ends with a page directed to parents, summarizing the day's lesson and suggesting simple follow-up activities. At an opening day family orientation, introduce parents to this page and express your hope that each week they will read it and review their child's entire lesson.

Dismissal

Lessons will simply indicate a few moments for dismissal. As every Kindergarten teacher knows, saying goodbye is as valuable an opportunity as welcoming students. A hug, a wish for the week, some personal connection with what's going on in the child's life ("hope your grandma's feeling better, Talin!") — all of these farewell activities can strengthen your relationship and make students all the happier to come to church on Sunday.

General Characteristics of 4-5-year-olds

Very active; imitators; attention span of five to ten minutes; enjoy playing with other children; forming concepts of social and physical reality; inquisitive; learning to relate to adults other than parents; big imagination; developing sense of right and wrong; learning to share; tire easily; growing vocabulary and letter and word recognition; reading readiness; curious.

Needs

Consistent discipline, stable environment, warm teachers who interact with them, frequent change of activities, consistent models of Christian behavior, explanation of new words, one teacher for five or six children.

Level of Understanding

Appreciate and enjoy learning that God created the world; think of God in personal terms; respond to Jesus with simple trust; love Jesus and want to please him; feel the love in church atmosphere; think of church as a happy, special place to go; can understand that the Bible contains important and exciting stories; can learn Bible words.

Activities

Drama, guided conversation, guided play, music, puzzles, books, simple art activities, story time, creative worship; see-and-touch displays.

Lesson 1: It's a Beautiful World!

Key Concepts

1. God made light, the sun, moon, and stars, land and water.
2. We read about Creation in the Bible.

Objectives

During this session, students will

1. Examine the display table.
2. Introduce themselves to their classmates.
3. Discuss personal, happy experiences.
4. Listen to the story of God's Creation.
5. Retell the story of Creation.
6. Start learning *Jashagestzook*, the prayer before meals.
7. Describe ways in which they enjoy God's world.
8. Recite the first verse of *Aravod Looso* (Morning of Light) in English.
9. Participate in a movement activity.

Materials Needed

1. On the display table, place the following suggested items:
magnifying glass, seashells, sand, rocks, a globe, cut-out shapes of the moon, sun, stars, etc., some books about the moon and the stars.
2. Pre-prepared sun-shaped yellow name tags with the child's name on one side; yellow crepe paper streamers each 12"-15" in length (two for each student); large yellow circle (the sun).
3. A Children's Bible with colorful illustrations.
4. Small yellow circle and white ones in a paper bag for activity in procedure #10.
5. Optional: A felt board with Bible story characters and elements.

Background for the Teacher

St. Nersess Shnorhali (1102-1173) was a great leader of the Armenian Church who became Catholicos in 1166. He was also a musician. He wrote many hymns; one of these is *Aravod Looso* which contains 38 verses, each starting with a different letter of the Armenian alphabet. He was a renowned poet and author of prayers, as well, such as the 24-verse *Havadov Khosdovanim* (I Confess with Faith), one verse of which is "Jesus Wisdom of the Father."

Procedure

1. Welcome children warmly and direct them to the display table. Encourage them to handle and look at the objects carefully, utilizing the magnifying glass. Stand to say the opening prayer together. 5 min.
2. Direct the children to the story corner. Say: "Tell your classmates your name as I put a name tag around your neck." After all of the children have said their names, say: "You saw a lot of things on our table this morning. Based on what you saw, what do you think our lesson will be about today?" 5 min.
3. Stand to say the opening prayer together. Then ask children to look at the picture of a child sitting up in bed. Begin by asking the opening questions in *Our Life Together*. Finish reading the paragraph. Ask: "Where have you seen people with smiling and happy faces? What were they doing?" Discuss these questions and the photos with your students. 5 min.

4. Show the children where the story of Creation appears in the Bible. Say: “At the very beginning of the Bible is a story about how God created our wonderful earth and all of the living things on it. Look at the picture in your lesson of the big, round white moon.” Read *God’s Word to Us*. 5 min.
5. Say, “I am going to read the creation story again (*God’s Word To Us*). This time I am going to ask you to help me. When I give you this signal (touch your hand to your lips) say the words – ‘*God saw that it was good and he smiled.*’” Ask the children to repeat this sentence a few times for practice. Remind them: “When I give you the signal, you will say, ‘God saw that it was good and he smiled.’” Begin to read, “In the beginning there was deep darkness everywhere...”
6. After you have finished, say: “You have just performed the creation story. What did God create for us?” If you have a felt board, use it at this time to review the story. 5 min.
7. Snack. Ask the children to join you at the table. Say: “Every Sunday, before we eat our snack, we are going to recite the *Prayer Before Meals (Jashagestzook)* in English. Today, I will recite it in English and Armenian.” Begin to teach the first line of the prayer in English. For example, say: “Today I would like you to learn the first line of the *Prayer Before Meals*: ‘Let us in peace eat this meal.’” Then you recite the same line in Armenian: “*Jashagestzook khaghaghootyamp uzgeragoorus.*” The children will not be memorizing the prayer in Armenian at this time, but they should gradually become familiar with it. Encourage them to do some of the serving and pouring and participate in the clean-up. 10 min.
8. Remain at the table. Say: “Please look at the page where you see children and grown-ups enjoying the outdoors.” Begin to read *We Learn About God*, stopping to ask the children to name some things they like to do in the sun. 5 min.
9. Now direct children’s attention to the picture of a saintly man writing. Read the passage from *Our Armenian Way* about St. Nersess Shnorhali (the Grace-filled) and the hymn that he wrote.
10. *Movement activity*: Say: “Please look at the beautiful, big, round sun in your lesson. We are going to learn the words to the hymn, *Morning of Light*, called *Aravod Looso* in Armenian, a hymn written by St. Nersess Shnorhali.”

Ask the children to stand. Say: “We are going to learn the first two words of the song in Armenian. Repeat these words after me – *Aravod Looso* – which means morning of light.” Begin to teach the paraphrased translation of the Armenian words into English. Say: “Repeat each line after me.” Continue this routine a few times until the children become familiar with the words.

Ask the children to go to an area of the room to begin the movement activity. Say: “Now that we know the words to the song, we are going to recite the words as we begin to move around the room. One of you will be the sun. The rest of you will be the rays of the sun, making everything shiny and bright.”

“I am going to pass around a bag with paper circles in it. Whoever picks the yellow circle will be the sun.” The child portraying the sun should hold a large yellow circle, while the other children hold yellow streamers, one in each hand. If there is time, the children should just walk around the first time, repeating the word *looy*s (light). (If there is not enough time, go directly to the song.) The second time, they should say or sing, with your help, the English verse of *Aravod Looso* as they perform the actions below:

Line 1 – The children are all kneeling on the rug. Tap the sun to stand; the others will follow as if they were waking up. They begin the hymn – *The sun greets me at dawn.*

Line 2 – The children, waving their streamers, walk freely around the room, moving with the sun. While moving, they say: *It shines upon the earth.*

Line 3 – In loud voices, they will all say the last line, *Light is everywhere*. When the activity is over, collect the circle and the streamers. Say: “Let us go to the story corner for a very special story.” 10 min.

11. Story Time: “Mary and Joseph”

After discussing the story questions, conclude: “Yes, and now that an angel has told Joseph Jesus would save the world, he and Mary waited for this great blessing.”

12. Dismissal.

10 min.

Lesson 2: Come to My Garden

Key Concepts

1. Flowers, plants and trees are God’s gifts to us.
2. We are the caretakers of the earth.

Objectives

During this session, students will

1. Examine the display table.
2. Listen to a story about a grandmother’s special meal.
3. Explain why the meal was so special.
4. Brainstorm ways to care for the earth.
5. Draw a picture of a garden.
6. Describe, with help, the *Antasdan* service.
7. Participate in an *Antasdan* service.

Materials Needed

1. On the display table, place the ceremonial cross (*Background for Teacher*); a bouquet of flowers; a rose; flower and/or vegetable seeds; magnifying glass; fresh basil (enough to give each child a leaf, a sprig or two); a few string beans.
2. For each child: white or manila construction paper (9"x12"), crayons, four different colored tissue paper circles 2"-3" in diameter to make flowers.
3. A Children’s Bible.

Background for Teacher

The Blessing of the Field (*Antasdan*)

In earlier times, this service was performed outdoors. Today it is performed mostly in churches. As a symbol for the four directions of the world, the east, west, north and south corners of the church are blessed by the priest who prays for abundance of crops and protection against natural disasters. Prayers are also requested for churches, cities, villages, the Catholicos, Armenia, the priests and for the people.

Prepare a simple processional cross to use during the *Antasdan* service which you will conduct outdoors (if the weather permits) or indoors. You can cut out an Armenian cross (at least 8" high). Tape it to a stick or ruler and tie some basil around the base of the cross. (Basil is a pungent, sweet-smelling herb, and is a symbol of royalty. Its name comes from the ancient Greek word *basilikos* meaning “royal.” You can wrap the cross and the stick in foil.

Procedure

1. Welcome children warmly and direct them to the display table. Encourage them to handle and look at the objects, utilizing the magnifying glass. Point out things for them to notice, e.g. the colors of the flowers, the beauty of the rose, the sizes of the flower seeds.
Ask: “Does anyone have anything to say about the objects on the display table today? What do you think today’s lesson will be about?”
2. Stand to say the opening prayer together. Sing the hymn *Aravod Looso* introduced last Sunday. 10 min.
3. Move to the story corner. Before reading the story, say: “Look at the picture of a grandmother in her garden. Today’s story is about her. How many of you have grandmothers who cook special meals for you?” Read the story and review it with the help of the children. Discuss the question at the end of the story. (Possible answers: the beans were from the grandmother’s garden; the friends were happy to be together; the stew was made with love.) 5 min.
4. Direct the children to the table. Say: “There are other gardens in your lesson. Can you find them?” Read *God’s Word to Us* and *We Learn About God* and brainstorm the question at the end of the paragraph. Help the children give examples like *do not litter, plant seeds, recycle, etc.*
5. Ask a child to distribute construction paper. “Today we are going to draw a beautiful flower garden. What kinds of things can you put in your picture?” They may suggest things like flowers, trees, birds, insects, sun. Say: “Before we begin to draw the flowers, we need to draw the grass and the sky. Begin to draw the grass on your paper. When you finish, draw the sky.” (It is always helpful if you demonstrate before you ask the children to draw.) Continue the rest of this activity after snack. Collect the papers, writing the child’s name on the back as you do, and get the table ready. 5 min.
6. Snack. Teach the second line of the *Prayer Before Meals* in English.
“Let us in peace eat this meal, which the Lord has prepared for us.” (Each week, you recite the prayer in Armenian, encouraging any of the children who wish to join you.) 10 min.
7. Return the papers to the children. Demonstrate how to make the flowers. Say: “We are going to finish our gardens. Take a tissue paper circle. Put a dot of glue on your paper and place only the center of the circle on it. Turn up the ends of the circle. Make three more of these.”
8. Ask: “What else can we add to our pictures?” Help the children think about adding the sun, some birds and butterflies to their pictures. (If there is time, the children can make additional flowers.) Share the pictures or display them on a wall in the classroom with the Bible quote (Genesis 1:11), “Let the earth grow plants and flowers, grass and trees.” 10 min.
9. Read *Our Armenian Way* and *We Celebrate*. If weather permits, take the children outside to celebrate a brief worship based on the *Antasdan*. (In this case, you might want to have story time first.) Say: “I am going to take you outside for a prayer activity that will remind us of the *Antasdan* service of the Armenian Church. Do you remember what the priest blesses during this service? (He blesses the four corners of the world.) For whom does the priest pray? (He prays for the people of the world.)” Remember to take the cross with you. Stand in a group with your students and face in one direction. One student should hold the cross. Ask everyone to say: “Bless the world and protect all who live in it. + In the name of the Father and of the Son and of the Holy Spirit. Amen.” If there is inclement weather, do the same thing indoors.
Say: “Now turn to your right to face in another direction.” Give the cross to another student to hold and repeat the blessing above. Do this until you have all returned to the place from which you started. 10 min.

10. Story Time: “Jesus is Born”

After discussing the story question, conclude: “At the end of our story an angel guided the holy family to Egypt. May an angel guide us all back to our homes today.”

11. Dismiss the class. Give each child a leaf of basil to take home, reminding them of the significance of the basil. 10 min.

Lesson 3: Bless This Table

Key Concepts

1. Jesus is generous, loving and kind.
2. We should be thankful to God for his gifts.

Objectives

During this session, students will

1. Examine the display table.
2. Participate in a discussion of God’s special gifts.
3. Recall the story of the miracle of the loaves and the fish.
4. Hear about the “Blessing of the Grapes” service.
5. Design a place mat with illustrations of grapes, bread and fish.

Materials Needed

1. On the display table, place cut-outs (or toy replicas) of two loaves of bread and five fish; bunch of grapes.
2. Colored construction paper (yellow, white), 11"x18"; scissors; crayons; *Prayer Before Meals* (see Appendix) to glue in the center of the mat; optional: stickers of fish, grapes and bread (fish can readily be found; the other two perhaps online or through catalogues).
3. A Children’s Bible.

Procedure

1. Welcome children warmly and direct them to the display table. Encourage them to look carefully at the objects.
2. Stand to say the opening prayer together. 5 min.
3. Move to the story corner. Say: “Look at the pictures of birthday presents and a cake.” Read *Our Life Together*. With the children, discuss the gifts that God has given to them (family, friends, food, pets). Also talk about birthdays, how they are celebrated and who attends. (You may want to have a list of the children’s birthdays posted somewhere in the classroom.) 10 min.
4. Remain in the story corner for the story of the miracle of the loaves and fish. Say: “Look at the picture of Jesus with a lot of people.” Use the paper cutouts or replicas of the bread and fish as you read the story (*God’s Word To Us*). 5 min.
5. Say: “Now look at the picture of a child lighting a candle.” Read *We Learn About God*. Gifts which may be named are: new baby, pets, food, beautiful weather, rain, visits from grandparents or other family members, a family birthday celebration or gathering. Accept what the child offers. In response to the question about saying thank you, remind the children, they can say a prayer of thanks or light a candle in church. 5 min.

6. Now have them look at the picture of the priests blessing grapes. Read *Our Armenian Way*. Tell the children that the priest, like Jesus who blessed the fish and the bread, blesses the grapes before they are given out to the people. 5 min.
7. Snack. This week teach the last line of the *Prayer Before Meals* in English – “Blessed is the Lord in his gifts. Amen.” Remember to say the prayer in Armenian every Sunday to allow the children to hear it and become familiar with it. 5 min.
8. Remain at the table. Read *We Celebrate* together. Then say: “To help us remember the miracle of the bread and the fish and the blessing of the grapes, you are going to make a place mat.” Give out yellow or white paper, 11"x18". Explain to the children that they will fringe the two short ends of their place mats. Demonstrate how to fringe. (They may need your help with this.)
9. “In the center of the mat, glue the *Prayer Before Meals*. Draw a bunch of grapes in each corner and draw two fish and five loaves of bread around the *Jashagestzook* prayer.” Help with the drawing and distribute stickers, if you’re using them (a combination of stickers and children’s drawings are better than stickers alone). They might also want to add some of the ideas they gave when answering *We Celebrate* questions. When they are finished, remind the children that the place mats will help them retell the stories to their parents. 15 min.
10. Story Time: “The Baby is Blessed”
After discussing story questions, conclude: “So here were Simeon and Anna finally seeing the baby they had waited so long for, the baby who would change the world. They were so happy they shared the good news. You, too, can share the good news of Jesus.”
11. Dismissal. 10 min.

Lesson 4: God’s Amazing Zoo

Key Concepts

1. God created the animals.
2. God wants us to care for them.

Objectives

During this session, students will

1. Examine the display table.
2. Participate in a discussion of animal habitats.
3. Listen to the Bible reading about the creation of the animals.
4. Review God’s message about caring for animals.
5. Learn about “bird letters.”
6. Color a bird letter representing the first initial of their name.

Materials Needed

1. On the display table, a book of bird letters (or just the one from today’s lesson), a globe, library book(s) with pictures of animals.
2. Other materials needed: crayons, optional: stick glue, sequins, shapes, etc. for children to decorate their letters with; bird letters (one for every child’s first name initial, available from the book *Aravod Looso*; if you do not have the book *Aravod Looso* (a copy was sent to every Sunday School), contact the

Department of Christian Education at the Diocese for the letters) crayons or colored pencils.
3. A Children's Bible.

Background for Teacher

Armenian artists have always been fascinated with nature, especially birds. In the 12th – 14th centuries, artists began to form letters of the alphabet into the shapes of fish and men as well as birds.

Some information you can share with the children: Wild animals - like bears, mountain cats, deer and boar - can be found in the mountains of Armenia. There are 346 different kinds of birds in Armenia. Some birds are year-round residents; others come for seasonal stays.

Procedure

1. Welcome the children and direct them to the display table, calling their attention to the bird letters.
2. Stand to say the opening prayer together. 10 min.
3. Invite the children to join you in the story corner. Direct children's attention to the pictures of animals on the opening page. Read *Our Life Together*. Have available reference books on animals from a local library and a globe. Show just a few pictures. Discuss questions. 10 min.
4. Read *God's Word To Us*. Say: "This story is found in the Bible where we read all about how God created the animals, the birds and the creatures living in the ocean. (You can hold up a Bible and point to Genesis.)"
5. Ask: "Where is the picture of a monkey?" Review *We Learn About God* together. Spend a few moments to ask the children about their favorite animals. 5 min.
6. Go to the table. Show some bird letters as you read from *Our Armenian Way*. Ask the children to repeat the Armenian word for bird letter – *turch-na-keer*. Say: "This word comes from the word, *tur-choon*, bird, and *keer*, letter." 5 min.
7. Snack. 10 min.
8. Read *We Celebrate*. Give out the bird letters and say: "This is a bird letter. It is the first letter of your name. Color (decorate) it." When the children have finished, tape the letters to a wall so they can spend time looking at them. 10 min.
9. Story Time: "In My Father's House"
Conclude story time: "Mary kept thinking about how special Jesus was. Let's remember all week about how special Jesus is to us."
10. Dismiss the class. 10 min.

Lesson 5: God Made You and Me

Key Concepts

1. God made us with love.
2. God wants us to love one another.

Objectives

During this session, students will

1. Examine the display table.
2. Listen to a story about two children.
3. Participate in a discussion to resolve their conflict.
4. Listen to a passage from the Bible.
5. Compare their names in Armenian and English with those of the other children in class.
6. Recite a prayer for the children of the world.
7. Play a matching game with international children's faces.
8. Make a prayer card.

Materials Needed

1. On the display table, place several pictures of children from diverse ethnic backgrounds; one or two books showing children from different countries; a globe; faces from the game "I Never Forget a Face."
2. Names of children in Armenian and in English (suggested size for each: 1½" x 5½"); for each child: oak tag approximately 5½" x 8"; *A Prayer for the Children of the World*; (see appendix), color reproduction of children's photos from *We Celebrate* (you can also go online for pictures of children of different cultures); crayons or markers; glue; hole punch; yarn or ribbon.
3. Matching Game: "I Never Forget a Face" (your Sunday School received a set from the Diocese). Have it set up for children to play with as they arrive.
4. A Children's Bible.

Procedure

1. Welcome children warmly and direct them to the display table.
Encourage them to look at the book(s) and the pictures. Help them play the matching game.
2. Stand to say the opening prayer together. 10 min.
3. Move with the children to the story corner. Before beginning the story, engage the children in a conversation about what they see in the picture. Read *Our Life Together*. At the end of the story, elicit from the children their responses to the questions. 10 min.
4. Remain in the story corner. Holding the Bible say, "God made each one of us, and the story is here in the Bible." Read *God's Word to Us*.
5. Go to the table. As a review, talk about Ara and Lucy, their problem, and its resolution. Read from *We Learn About God*. 5 min.
6. Stay at the table for the name activity. As you distribute the papers with the names of the children in Armenian and English, say: "These words spell your names in Armenian and English letters." Hold up the names; say the child's name as you give them to him/her. Say: "Our names are different, and the letters of our names are different. Look at a friend's paper. Does his or her name look like yours?" After a few minutes to allow the children to compare names, say: "Now you are going to glue your names on your lesson page. When you finish, copy or trace the first letter of your name in Armenian right next to where you pasted your names. I will help you" 10 min.
7. Snack. 5 min.
8. Say: "Now look at the faces of children from different parts of the world." Read *We Celebrate*.

Say: "Today we are going to make a prayer card. On this card, we will glue a prayer like the one we just recited." Distribute the prayers, oak tag, and photos. Help children glue the prayers in the middle of the oak tag and the photos on one side. Leave space for their own drawing.

Hold up face cards from the matching game; pointing to these and the pictures in the text, say: "These children are from different places all over the world. Now somewhere on the card, draw a picture of yourself."

When children have finished, make a hole at the top of the prayer card, and loop a strip of ribbon through the hole. As you hand the finished cards back, say: "When you take the prayer card home, share it with your family and decide where to hang it in your home to remind you of God's words: 'Love one another!'" 10 min.

9. Story Time: "This is My Son"

Conclude story time: "In the wilderness, Jesus had to think hard about who he was and what he was going to do. He spent his time praying. Let's try to follow Jesus and pray more this week."

10. Dismissal.

10 min.

Lesson 6: God is Love

Key Concepts

1. God is a loving, caring and forgiving God.
2. God loves us.
3. Our families love us.

Objectives

During this session, students will

1. Examine the display table.
2. Respond to questions about an imaginary merry-go-round ride.
3. Recite John 13:34.
4. Discuss how we can share God's love.
5. Memorize the words *Asdvadz Ser Eh*/God is love.
6. Perform the chant – Love One Another.
7. Make a love bracelet.

Materials Needed

1. On the display table, the following items are suggested: a LOVE bracelet*; the word LOVE printed on a piece of paper (8"x10"); any pictures cut from magazines showing parents and children (grandparents, too) and friends.
2. Ribbon or yarn; scissors; beads for each child to spell LOVE.
3. A Children's Bible.

* This is made with individual beads or small squares with letters printed on them that can be strung on a ribbon or chain; these are widely available in craft stores or arts and crafts catalogues.

Procedure

1. Welcome children warmly and direct them to the display table. Encourage them to look at the objects. Say: "Who can find the word love on the table?"

2. Stand to say the opening prayer. 5 min.
3. Move to the story corner. Say: “Let’s look at the pictures of merry-go-rounds.” Begin to read *Our Life Together*. Read the entire story, taking time to ask and discuss the questions. 10 min.
4. Say: “In the Bible passage today God tells us about love.” Read *God’s Word to Us* and *We Learn About God* and discuss the questions at the bottom of the page. 5 min.
5. Say: “Look at the picture of an altar.” Read *Our Armenian Way*. “In this lesson, we remember that God loves all of us, and we should always remember his words, ‘Love one another as I love you.’” Explain briefly the meaning of the words *loving, caring and forgiving*. Then introduce and teach the words *Asdvadz ser eh*/God is love in Armenian and English. 5 min.
6. Snack. 10 min.
7. Say: “We are going to make love bracelets.” Read from *We Celebrate*. Hold up the word LOVE from the display table. Ask: “What does God want us to do?” (Love one another.) Say: “I am giving each of you the letters that will spell the word *Love* along with some ribbon. How do we spell love? Look at the card. L – O – V – E spells LOVE. ” (Some of your students may need additional help.)
Say: “Begin to put your letters on the ribbon. Bring your bracelet to me when you are finished so I can tie it around your wrist.” Say: “Come and stand in a circle. Now I am going to teach you a chant, a kind of poem. It is called “*Love One Another*.” Refer to *We Celebrate*. “I will say a line, and you echo the words that I say.” Recite both verses. If there is time, repeat the chant one more time. The children can try to snap their fingers or clap their hands. Whisper the line, *love one another*. 15 min.
8. Story Time: “Follow Me”
Conclude story time: “Jesus began his wonderful work with a special group of followers, people who would listen, and learn and then teach others. We are his followers today!”
9. Dismiss the class. 10 min.

Lesson 7: Noah and A New World

Key Concepts

1. God created life again with Noah and his family.
2. God pledged his love with the sign of a rainbow.

Objectives

During this session, students will

1. Examine the display table.
2. Listen to a story about a girl named Ani.
3. Listen to a Bible passage about Noah and the ark.
4. Discuss the wonders of God.
5. Review the story of Noah.

6. Name one thing they learned about Mt. Ararat.
7. Make an olive branch to use in a retelling of the story of Noah.

Materials Needed

1. On the display table there should be a picture of the ark or, even better, an age-appropriate toy Noah's ark; a sample of the olive branch to be made by the students; a jar of olives; olive oil; pictures of rainy days; a small umbrella; a rain hat.
2. For each child: copy of the ark to be glued in student text and leaves traced onto green construction paper for the olive branch (see appendix); twigs (check at a garden store or florist if you can't collect them yourself); crayons; scissors; glue.
3. A Children's Bible.

Background for Teacher

Numerous expeditions have been made to the summit of Mt. Ararat in search of the ark. There are many legends concerning a great ship on Mt. Ararat. The two peaks of Ararat are known as Greater Massis (Ararat) or Lesser Massis (little Ararat).

Genesis 8:5 tells us that after the ark landed, it took several months until the tops of the other mountains could be seen. Mt. Ararat is the highest mountain in the area. It is covered with snow and glaciated year round. These conditions would help to preserve the ark. The search for Noah's ark continues!

Olive trees were very important to the people of Jesus' time. Olives were a basic food. They were eaten pickled and spiced. But even more importantly, the olive fruit would be crushed to produce oil. Olive oil was used extensively for cooking and as fuel for lamps. In the dry climate, it was also a soothing ointment. Finally, it was used to anoint people, setting them apart for a special job. Priests and kings were anointed. We are anointed with oil when we are chrismated.

Procedure

1. Welcome children warmly and direct them to the display table. Talk about the olive branch and olives-using *Background for Teacher* information-as well as rain and rainy days.
2. Gather to say the opening prayer. 10 min.
3. Direct the children to the story corner. Read *Our Life Together*. Ask: "Have you ever had to stay inside your house because of a severe rainstorm just like Ani in the story? What did you do?"
4. Say: "I am going to tell you a story about a rainstorm which lasted not one day, not two days, not three days but forty days and forty nights. It is the story of a man named Noah who always did what God told him to do. Turn the page to where you will find a large boat, called an ark." Read *God's Word to Us*.
5. Go to the table. Read *We Learn About God*. Encourage the children to comment on the observations. 5 min.
6. Snack. 10 min.
7. Say: "Now look at the picture of the two mountains." Read about Mt. Ararat (*Our Armenian Way*). Distribute the arks which will be pasted in the student's lesson. "Name one thing we can add to our picture? (dove) Yes, and let's draw one now. (Distribute crayons.) What is another thing we can add? (rainbow) Let's draw one now over Mt. Ararat. And now, tell me one thing you remember about Mt. Ararat." Remind the children how much God loves us. The rainbow is God's promise that he will always love us. 10 min.

8. Read from *We Celebrate*. Say: “Today we are going to make a little branch of olive leaves like the one the dove brought back from dry land to Noah.” Ask one of the children to distribute the twigs and 4 leaves, 3 large and one small. Have the children cut out the leaves. Then go around, taping each child’s leaves on their branch. Have the children sit, stand or walk in procession as you re-read *God’s Word To Us*. They may raise their branches of leaves when you reach the line “The dove flew back with an olive branch....” 15 min.
9. Story Time: “His Loving Touch”
Conclude story time: “Jesus told the sick boy’s father ‘Everything is possible when you believe.’ This week let’s ask Jesus to help us believe even more.”
10. Dismissal. 10 min.

Lesson 8: Mary the Mother of Jesus

Key Concepts

1. Jesus is God’s Son.
2. Mary is Jesus’ loving mother.

Objectives

During this session, students will

1. Examine the display table.
2. Listen to the stories of two pious women who did something beautiful for God.
3. Name ways *they* can do something beautiful for God.
4. Listen to the story of the Annunciation.
5. Make a triptych showing the Annunciation.
6. Retell the story of the Annunciation.
7. Learn to sing or to say “*Mary’s Song*.”

Materials Needed

1. On the display table place a few pictures from magazines or actual photographs of mothers, grandmothers, etc. with children. Also display a picture of Mary with baby Jesus, Mother Theresa and Tsuveeg (use the student lesson pages).
2. Other materials needed for the day’s lesson: precut triptych, precut oak tag (in triptych shape), crayons; colored pencils; scissors, glue; glitter; optional: musical instruments (see procedure #8)
3. A Children’s Bible.

Background for the Teacher

Tsuveeg lived in the 5th century, the daughter of the Arzruni prince Vasag (also known as Vram) and wife of St. Vartan’s martyred brother Hmayag. She was a highly educated and pious Christian woman. She was widowed at a young age and devoted her life to her sons and to good works.

Procedure

1. Welcome children warmly and direct them to the display table. Call their attention to the pictures and photographs on the table, identifying Mary, Mother Theresa and Tsuveeg.
2. Stand for the opening prayer. 10 min.

3. Move to the story corner. Read *Our Life Together*. Say: “Mother Theresa and Tsuveeg did beautiful things for God. What are some beautiful things you can do for God?” (Some answers you might hear: say a prayer, go to church, attend Sunday School, help parents, be kind to others, draw a picture for someone, play fairly with a friend, plant a seed or a flower.) 5 min.
4. Direct the children’s attention to the picture of an angel and St. Mary. Read the text, *God’s Word To Us*. Ask the children, “Do you remember the words of the angel Gabriel to Mary? What was Mary’s answer?” Read from *We Learn About God*. 5 min.
5. Say: “ Now let’s look at the picture which has three parts. This picture with three parts is called a triptych. Boys and girls, point to the center panel. This is Mary (Maryam) and the angel Gabriel. The Armenian word for angel is *hreshdag*. What is the angel saying to Mary? What is Mary saying to the angel? What the angel told Mary is called the Annunciation. The word “annunciation” means “something that is announced.” (Next, point to the picture of the candle.) In Armenian, it is called *mohm*. (Now point to the picture of the rose.) In Armenian, it is called *vart*.” The beautiful rose is a flower we associate with St. Mary. 5 min.
6. Snack. 10 min.
7. Distribute the triptych. Have the children color it and when they are finished they can cut it out. Distribute glue for children to glue the triptychs onto oak tag. Fold into thirds. Help them glue and sprinkle glitter on the haloes. The children can place the triptychs on the display table for everyone to see. 15 min.
8. Move to another area of the room where the children can stand to learn “*Mary’s Song*.” With the children, review the story and explain that this song was written just for Mary to show her how much we love her. Proceed to teach the words in Armenian and English. You can sing or say the verses. If you have access to musical instruments for young children, for example tambourine, triangle, sticks, use them as accompaniment to the song. 5 min.
9. Story Time: “A Way to Live”
Conclude story time: “We call the beautiful prayer Jesus taught us ‘The Lord’s Prayer’ – in Armenian, the ‘Hayr Mer.’ It is one of the many beautiful prayers you will learn in Sunday School.”
10. Dismiss the class. 5 min.

Lesson 9: Jesus is the Light of the World

Key Concepts

1. Jesus is the Son of God.
2. Jesus came to bring the message of hope and forgiveness.

Objectives

During this session, students will

1. Examine the display table.
2. Talk about cousins and friends.

3. Identify John the Baptist as a friend and cousin of Jesus.
4. Recall why God sent Jesus to us.
5. Sketch a special person in their lives.
6. Tell what happens at the *Jurakalooytz* service.
7. Make a lantern.
8. Learn and sing the “*Song of the Lanterns.*”

Materials Needed

1. On the display table place a finished lantern; magazine pictures of children playing; family photographs; a candle; flashlight; storm lantern or other type of lantern.
2. Pattern for lantern (see Appendix), precut lanterns (gray or brown construction paper – 2 folded sheets (17" X 22") per lantern), 1 sheet of yellow cellophane or tissue (5"x7"), glue. Lanterns need to be cut and ready before class begins. To make the lantern, there should be two pieces (front and back) for each child.
3. A Children’s Bible.

Procedure

1. Welcome children warmly and direct them to the display table. Discuss various light sources and the importance and benefits of light.
2. Stand to say the opening prayer together. 5 min.
3. Move the children to the story corner. Discuss *Our Life Together*. At this time, ask the children to think of the name of a good friend or cousin. You will need to write that name on the line provided. 10 min.
4. Read *God’s Word To Us*.
5. Move the class to their table. Say: “Find an empty space with a red line around it in your lesson. It is going to be a frame for the picture you are going to draw.” Read *We Learn About God*. Say: “I would like you to draw a picture of someone who loves you, who helps you and forgives you.” Offer suggestions, if needed. 5 min.
6. Snack. 10 min.
7. Read *Our Armenian Way*: “In your lesson, find the page with music. We will learn this song after we finish making lanterns. At the end of the *Jurakalooytz* service, all of the lights and candles in the church are lit. We are going to make a paper lantern to remind us of that service. *Jrak* means lantern in Armenian.” Ask the children to help you give out the supplies. Each child should get two gray (or brown) shapes and one sheet of yellow cellophane or yellow tissue paper to glue between the two shapes. 15 min.
8. Say: “And now we are ready to learn *The Song of the Lanterns*. You already know the tune of the song. Listen to the words. Say the words after me.” Sing the song once for the children. “Now let’s sing the song.” As a culmination, let the children walk around the room singing the song and waving their lanterns. 5 min.
9. Story Time: “Birds and Lilies”
Conclude story time: “How happy these people must have been to be helped by Jesus. And everyone was amazed just like we are when we read this story from the Bible.”
10. Dismissal. 10 min.

Lesson 10: A Holy Family

Key Concepts

1. Mary, Joseph and Jesus were a holy family.
2. My family is a holy family too.

Objectives

During this session, students will

1. Examine the articles on the display table.
2. Discuss the photographs of different families.
3. Review the early life of the Holy Family in Nazareth.
4. Brainstorm ways to be thoughtful, kind and helpful like the Holy Family.
5. Memorize the Litany for Families.
6. Participate in a modified Home Blessing service.

Materials Needed

1. On the display table, place several pictures of families cut from magazines and/or use personal photographs; pictures of the Holy Family and/or stand-up or plush figures of Mary, Joseph and a young Jesus; ingredients for a home blessing (incense, salt, bread, water), table cloth.
2. A Children's Bible.

Procedure

1. Welcome children warmly and direct them to the display table. Encourage them to look carefully at the display. Point out the photographs, using the word *family* whenever possible and describing actions, e.g. hugging, laughing, playing, etc. Answer any questions the children may ask about the four ingredients.
2. Stand to say the opening prayer together. 10 min.
3. Go to the story corner. Read from *Our Life Together*. Referring to the photographs, use words such as *sharing, smiling, hugging, giving, playing* to communicate the idea that happiness is created within families. With your help, the children will conclude that being together makes families happy. 5 min.
4. Tell children to look at the picture of Mary on a donkey. Read *God's Word to Us* and then *We Learn About God*. As part of your dialogue with the children, discuss the way(s) in which our families can be thoughtful, loving and kind like Jesus and his family.
5. Recite the Litany for Families and then ask the children to repeat the words line by line after you. 10 min.
6. Snack. 10 min.
7. Say: "Turn in your lesson to where you see a picture of the four things the priest needs for a home blessing." Read *Our Armenian Way* and *We Celebrate*. 5 min.
8. Review with the children how to make the sign of the cross while saying "Hanoon Hor yev Vortvo yev Hokvooyrn Srpo. Amen." (In the name of the Father and of the Son and of the Holy Spirit. Amen.) Say: "We are going to pretend our home is being blessed. Of course, this is always performed by our pastor, Father _____. When he visits your house, he will stand with you around a table just as we

are doing. On the table will be incense (he brings that with him), bread, water and salt.” (Ask the children to help you.)

“When we begin, I want you to say, ‘Amen. Alleluya. Alleluya. Alleluya.’” Read the Prayer of Blessing. With the children say, “Hanoon Hor yev Vortvo yev Hokvooyin Srpo. Amen. In the name of the Father and of the Son and of the Holy Spirit. Amen.” Repeat three times. 10 min.

9. Story Time: “A Farmer Planting Seeds”

Conclude story time: “We can be like the good soil whenever we hear Jesus’ words. Then our love for him and everyone can grow strong.”

10. Dismissal.

10 min.

Lesson 11: This is My Son

Key Concepts

1. John the Baptist baptized Jesus.
2. God manifested himself by sending the Holy Spirit in the form of a dove to seal the baptism of Jesus.

Objectives

During this session, students will

1. Examine the display table.
2. Listen to a story about the baptism of a baby.
3. Listen to a story of Jesus’ baptism.
4. Retell, using pictures, the story of Jesus’ baptism.
5. With your help, name the members of the Holy Trinity present at Jesus’ baptism.
6. Explain the roles of the godmother and godfather at the baptism.
7. Make a paper dove to represent the presence of the Holy Spirit at Jesus’ baptism.
8. Chant the hymn “Amen Alleluia.”

Materials Needed

1. On the display table, place a completed paper dove to be made by the children; picture of John the Baptist baptizing Jesus (try to find a picture which also shows the dove); a picture of a child being baptized in an Armenian Church (if possible, try to obtain an actual photograph of a student); a bottle of water; an article of white clothing; a small clear bottle of baby oil; (use these to discuss the water in the font, the white clothing babies are dressed in after being baptized, and the muron),
2. For each child, pre-cut doves (see Appendix for instructions); light weight white paper for wings; clear tape; string; scissors. You will probably need an assistant for this activity.
3. A Children’s Bible.

Background for Teacher

In Armenian, the word for baptism is *mugrdootiun*. The baby is “dipped” in the baptismal font three times. After the baby is dried, the priest blesses and anoints with holy oil nine parts of the body. The children will be interested to know which parts: the forehead, eyes, ears, nostrils, mouth, hands, heart, back and feet. This is called chrismation or *troshtm*.

The godmother dresses the baby in white, and then the priest presents the baby to the Holy Altar to receive Holy Communion for the very first time. The Armenian word for communion is *haghortootiun*.

Procedure

1. Welcome children warmly and direct them to the display table. Encourage them to look carefully at the objects.
2. Stand to say the opening prayer together. 5 min.
3. Move the children to the story corner. Say: “Look at the picture of the priest baptizing a baby.” Read *Our Life Together*. Go over the story, asking questions to help with the retelling such as, “What was the first thing Der Hayr did with the baby? (said prayers, put her in the water) When did he bless the baby with holy oil?” (After the baby was put in the font and dried.) You can use the information in the Background for Teacher to supplement the material in *Our Life Together*. 10 min.
4. Holding the Bible say, “Today’s Bible reading is about the baptism of Jesus in the River Jordan by his cousin John.” Read *God’s Word To Us*. Use the page to review the baptism of Jesus Christ. Read *We Learn About God*. This may be a time to review the Holy Trinity without going into too much detail. You can say, “While John the Baptist was baptizing Jesus, God the Father was watching from heaven. God sent the Holy Spirit down to the River Jordan as a dove (use the paper dove from the display table).” As you move the dove downward, say: “The dove flew down above Jesus, and God’s voice said, ‘This is my Son, and I am so pleased with him.’” Repeat: “God the Father, Jesus the Son and the Holy Spirit were all there at the baptism.” Ask: “What did God’s voice say as the dove came down?” (This is my Son. I am so pleased with him.) 5 min.
5. Snack. 10 min.
6. Say: “Let’s look at this picture of Der Hayr, baby Araxie, and her godfather and godmother.” Read from *Our Armenian Way*. The people in the drawing are baby Araxie’s godmother and godfather. You also had two very special people at your baptism – your godfather and your godmother. Say: “Ask your mom or dad who your godparents were. They can write their names in your lesson.” (Show the children where.) 5 min.
7. Distribute the precut doves and the white sheets of paper to make the accordion-pleated wings. Help the children as they pleat the wings. Make a slit in the side of the dove where the folded paper will be inserted. Insert the folded paper through the slit, spread open the folded paper, tape ends together at the top. Put string for hanging where the wings are joined. Go to an area of the room where the children can stand to learn the hymn, “Amen Alleluya.” Once it is learned, they can sing the hymn while flying their doves. 15 min.
8. Story time: “The Happy Wedding”
Conclude story time by repeating the last line and then say: “Yes, there are so many miracles that Jesus performed out of love and to show the glory of God, and we will be reading about them all together.”
9. Dismissal. 10 min.

Lesson 12: Jesus Loves Us

Key Concepts

1. Jesus welcomed people, especially children, to come to him.
2. God hears our prayers.

Objectives

During this session, students will

1. Examine the display table.
2. Listen to a story about a Sunday School class on the day of their priest's visit.
3. Hear a Bible passage about Jesus' love for children.
4. Recall that God hears us through our prayers.
5. Listen to and repeat the prayer "Jesus, Wisdom of the Father" by St. Nersess Shnorhali.
6. Listen to the Parable of The Lost Sheep.
7. Create a wall mural of the parable.
8. Retell the Parable of The Lost Sheep using props.
9. Sing, "Tender Shepherd."

Materials Needed

1. On the display table, place a picture of Jesus with the children (you can use the one on the cover of *Jesus*); the figures of a shepherd, a sheep, and a lamb, to be used on the mural later in the lesson (see patterns).
2. Brown wrapping paper 24"x 30" on which you have drawn a few hills. Dark brown construction paper for rocks (to be made and added by the children to the mural). After listening to the Parable of The Lost Sheep, the children will create a mural and use it to retell the story. The mural should be on a wall in the classroom when the children arrive.
3. Copy and precut one sheep, one lamb and one shepherd for each child. You may want to ask for parent help with this project. At the end of the lesson, each child should take home a lamb and a shepherd to share the story with his/her family; cotton; glue; crayons; scissors; masking tape.
4. A Children's Bible.

Procedure

1. Welcome children warmly and direct them to the display table. Encourage them to look carefully at the picture of Jesus and the children. Say: "What do you think Jesus is saying to the children?" Direct their attention to the figures of the shepherd and the lamb. Say: "We will hear a story today about this shepherd."
2. Stand to say the opening prayer. 10 min.
3. Move the children to the story corner and direct their attention to the picture of a priest with children. Read *Our Life Together*.
4. Say: "Look at Jesus with the children. How can you tell that Jesus loves them?" Read *God's Word To Us*.
5. Direct the children's attention to the picture of a child running to his grandfather. Read *We Learn About God*. Ask: "Why did Jesus want the children to come to him? When your grandmother plays a game with you, do you feel loved? When your aunt comes to spend the day just with you, do you feel loved? When you and your dad go out for breakfast on Saturday mornings, do you feel loved?" Say: "Repeat these words after me, 'God loves me and listens to my prayers.'" 5 min.

6. Snack. 10 min.
7. Ask children to find the picture of a priest writing a prayer. Read from *Our Armenian Way*. Say: “St. Nersess was a priest. He wrote prayers, and music and poetry.” Read the prayer, explaining the meaning of the words. Ask the children to repeat the prayer, line by line, after you.
8. Now say: “I am going to read you a story that Jesus told to help us understand how much God loves us. It is called The Parable (which is a story) of the The Lost Sheep.” Read *We Celebrate* . Say: “With this story, Jesus was trying to tell us that God loves us. When we are in trouble and need help, he will help us just like the shepherd who saved his lamb.” 5 min.
9. Go to the mural and say: “On the mural, I have drawn some hills. First, you are going to help me add some things to the mural. Using brown paper, cut out some rocks and glue them on the mural. With your green crayon, draw some grass on the mural.” Give out two lambs to each student and say: “We are going to glue cotton on to their bodies, but before we do that, I want you to take a black or brown crayon and color their faces and ears. Then you can glue some cotton on to the bodies. When you have finished gluing the cotton, place one of your lambs, using masking tape, somewhere on the mural.”
Once the lambs are on the mural, say: “Who can tell me how the story began? (Place a shepherd on the mural.) What happened next?” Ask a child to place one of the lambs on the mural near some rocks. Say: “What was the shepherd’s problem? What did he decide to do about it? Did the story have a happy ending? At dismissal, I will give you a shepherd to take home with your lamb so that you can tell your family the story of The Lost Sheep.” 15 min.
10. Teach and sing the song, “Tender Shepherd.” 5 min.
11. Story Time: “Winds and Waves Listen”
Conclude story time. “The disciples were wondering, ‘Who is this man who is ruler of all of nature?’ Sometimes we too ask questions like this, and here in Sunday School we learn some very good answers about who Jesus is.”
12. Dismissal. 10 min.

Lesson 13: We Prepare for Christmas

Key Concepts

1. *Heesnag* is the fifty-day period before Christmas.
2. Advent or *Heesnag* is a time of preparation for Christmas.

Objectives

During this session, students will

1. Examine the display table.
2. Listen to a story and discuss ways their families prepare for Christmas.
3. Retell the story of Mary’s visit to Elizabeth.
4. Discuss ways to prepare for Christmas.
5. Recall, with help, the meaning of Advent or *Heesnag*.
6. Make a *Heesnag* chain.
7. Recite the Advent rhyme.

Materials Needed

1. On the display table, place a manger scene – large plush figures are best; a picture of Mary and Elizabeth (may be found in a Bible or you can use the student text), Christmas cards; Christmas lights; a small Christmas tree; *Heesnag* chain.
2. For the *Heesnag* chain, cut 50 strips of paper 3"x 9", 49 red and green and 1 gold or white; prepare several links in advance for demonstration; star stickers; thin markers; stapler. You may want to get parent volunteers for this project. Check a church calendar for the beginning of the Advent season. Each week until Christmas, you'll have the children remove seven links from the chain. You can change the number in the Advent rhyme to correspond to the number of links left on the chain. Remove seven of the links today. The gold/white link represents Jesus and Christmas day. Consider hanging the removed links in the classroom in groups of seven.
3. A Children's Bible.

Procedure

1. Welcome children warmly and direct them to the display table. Encourage them to look carefully at the *Heesnag* chain (do not identify it).
2. Stand to say the opening prayer together. 10 min.
3. Move the children to the story corner. Referring to the picture on the first lesson page, say: "I wonder what these two children are doing? Any ideas?" Read from *Our Life Together*. Then ask: "So what were these two up to? After children answer, continue: "Yes, they were getting ready for Christmas. What happened long ago that we celebrate on Christmas?" (Use the manger scene to retell the Christmas story in its basic details: Jesus was born in a stable and lovingly placed in a manger by his mother Mary and father Joseph. Angels announced the birth of Jesus, the Son of God, to shepherds in the fields. A bright star over the stable guided the three wise men to where they could find the blessed baby, etc.)
Continue: "But let's back up to the time when Mary learned she would have a baby. What did she do to prepare? The first thing she did was share this good news with someone she loved, her cousin Elizabeth (you might want to ask if the children have cousins they are close to). Let's read about it." 5 min.
4. Read *God's Word To Us*.
5. Snack. 10 min.
6. Return to and read *We Learn About God*. "People prepared for the birth of Jesus in different ways. What are some of the ways *you* might prepare for Christmas?" Discuss the list and ask for additional ideas. 10 min.
7. Read or teach *Our Armenian Way*. Then ask, "What does Advent mean? (Something's coming.) What do we try to do during Advent or *Heesnag*? (Pray more, read the Bible, be as good as we can be.)"
8. "Now we are going to make an Advent chain like the one in our lesson. It will help us remember that there are 50 days during the period of *Heesnag*." Read the Advent verse.
Say: "Here we have strips of red and green paper and one gold (white). The gold (white) one will remind us of Jesus and the day he was born. I am going to give each of you some paper strips. On each strip, you can place a star sticker or you can draw something you see at the Christmas season like a candle, an ornament, a Christmas tree, a cross. When you finish, bring the strips to me, and I will give you some more." Distribute strips among children. As they bring their strips to you, staple them in a chain of links to make an Advent Chain.

When the Advent Chain is completed, add the gold or white link and teach the Advent verse.

The children can move in a circle, each holding a part of the chain, while they recite the verse. Gather the children around you as they help you remove seven links from the chain. Hang these on a wall in the classroom. Each week, seven links will be removed from the chain and the verse recited, naming the number of days left for Christmas. 15 min.

9. Story Time: “Who Is My Neighbor?”

Conclude story time by saying: “Jesus taught us this beautiful lesson about what a truly good neighbor is. Let’s try to be good neighbors this week.”

10. Dismissal.

10 min.

Lesson 14: Jesus Is Born!

Key Concepts

1. God is with us always.
2. God sent us Jesus, his son, as a sign of his love.

Objectives

During this session, students will

1. Examine the contents of the display table.
2. Explore the concept of “gifts of love.”
3. Listen to the story of God’s gift of love, the birth of Jesus.
4. Share birthday celebrations.
5. Describe how the Armenian Church family celebrates Jesus’ birthday.
6. Hear St. Gregory of Nareg’s prayer about angels.
7. Make a guardian angel.
8. Recite a line from the prayer by St. Gregory of Nareg.
9. Recite the Avedis Chant.

Materials Needed

1. On the display table, place a sample of the angel (see Appendix) to be made by the children; a manger scene; books or pictures depicting the Holy Family and the shepherds receiving the good news; Christmas paraphernalia.
2. Crayons; colored pencils; glitter; scissors. Precut guardian angels out of heavy-stock paper. Make copies of the line from the St. Gregory of Nareg prayer (see Appendix) to be glued on to the angel’s robe.
3. A Children’s Bible.

Procedure

1. Welcome children warmly and direct them to the display table. Encourage them to look carefully at the objects. Pointing to each figure in the manger ask, “Who is this?” Identify the figures if the children do not know.
2. Stand to say the opening prayer together. 10 min.
3. Move to the story corner. Read *Our Life Together* and talk about the photos of parents and infants and a birthday celebration.

4. Then direct children's attention to the picture of *another* family. Discuss the picture – Mary, the baby, the Wise Men, the animals (Joseph may be out gathering firewood!). Read *God's Word To Us*.
5. Now read *We Learn About God*. Share answers to the questions. 10 min.
6. Move to the table. Ask children to find the picture of the angel. Read from *Our Armenian Way* and then break for snack.
7. Snack. 10 min.
8. Distribute the guardian angels and the prayer strip to be glued to the angel's robe. Show the children the angel that was on the display table. Say: "Color your angel. When you have finished, glue St. Gregory's prayer on the front of the angel's robe. Next sprinkle some glitter on the angel's wings." Go over the line from the prayer – *Guardian Angel, help me to do good things*. Ask the children to repeat it with you. Remind them to place their angels somewhere at home where they can see it every day.
Say: "Stand in a circle. Hold your guardian angels in front of you and recite the prayer one more time." 15 min.
9. Look at *We Celebrate* together and then ask: "Do you remember what *Avedis* means? Yes, it means Good News." Teach the words of the chant.
10. Ask the children to stand. They can recite it in unison.
They can recite it in groups, one group saying the words, the other group saying *Avedis*. Each time they say the word *Avedis*, they can clap three times. 5 min.
11. Story Time: "Lord, We Have Faith!"
Conclude story time by repeating the last paragraph of the story and say "This week let us look at the birds and the trees around us and remember God takes care of us all."
12. Dismissal. 10 min.

Lesson 15: Jesus Called the Disciples

Key Concepts

1. Jesus chose twelve men to be his disciples.
2. Thaddeus and Bartholomew went to Armenia to teach the good news of Christ.
3. Armenia became the first Christian nation in 301 A.D.

Objectives

During this session, students will

1. Examine the display table.
2. Listen to a story about a boy's first day at a new school.
3. Explore the characteristics of a disciple of God.
4. Recall how Thaddeus and Bartholomew went to Armenia.
5. Recite a Friendship Chant.
6. Make a Friendship Tree displaying Jesus and the disciples.

Materials Needed

1. On the display table, prop up the pictures of Jesus and the disciples (see #2 below). If possible, have magazine pictures of people helping others (tutoring, meeting, nursing, etc.); a map of Armenia.
2. Polaroid camera for instant pictures (or digital and photos can be added later); glue; scissors; masking tape; brown wrapping paper for the Friendship Tree project. For the project, draw a tree at least three feet tall. Tape the tree somewhere in the room.
3. For Friendship Tree pictures, reproduce (in color) pictures of Jesus and the apostles from the student lessons (choosing from: 1:3; 3:2; 6:2; 8:1,2,3; 12:2,3; 15:3; 18:2; 27:2; 28:2,3,4) as well as the *Jesus* reader (choosing from: pp 10, 22, 26, 30, 42, 44, 46, 52, 54). If it's easier, use an extra copy of the student text and the *Jesus* reader and cut them out. Laminated, these can serve as Friendship Tree pictures for years to come.
4. A Children's Bible.

Procedure

1. Welcome the children warmly and direct them to the display table. Discuss the pictures of Jesus, the disciples, and people helping others. Tell the children that Jesus needed helpers and they'll be finding out more about that today. Discuss reasons people need helpers (even if pictures are unavailable). To save time, take a snapshot of each child as they arrive.
2. Stand to say the opening prayer. 5 min.
3. Direct the children to the story corner. Read *Our Life Together*. Ask: "Will Ara feel much better now? Why? What would you do if you saw a child in your class who looked sad?" 5 min.
4. "Now let's look at the picture of Jesus walking with his friend, the disciple Peter. You are going to hear a story about Jesus' disciples. They were also Jesus' friends." Read from *God's Word to Us*.
5. Read *We Learn About God*. Say: "Let us go over the questions on this page." Read each question. Then say, "If you can answer yes to the question when I read it, draw a smiley face on the line." Read and discuss each question. When you have finished the list, say: "Repeat after me. 'I am a disciple of Jesus.'" 10 min.
6. Have children look at the map of Armenia. Point out that Armenia is a long way from Jerusalem where Jesus was. Read from *Our Armenian Way*.
7. Snack. 10 min.
8. Review with the children the meaning of disciple. Say: "The disciples were good friends of Jesus. Think about one of your friends. Tell me. Is he or she kind? Will he or she help you? Will he or she share with you? Are you kind and helpful? Do you share with your friend?"
9. Read the Friendship Chant in *We Celebrate*. As you say the chant for a second time, ask the children to join you. (The children can walk around reciting the chant and shaking hands.) 5 min.
10. Point to the Friendship Tree you've pasted on the wall. Hold up and discuss pre-prepared pictures as you distribute them among the children. Glue the picture of Jesus with the children to the top of the tree, and then have the children glue the other pictures where you decide they should go (space them out). Have each child add their own photo to the tree. When the activity is finished, go over the disciples' names with the children and recite the Friendship Chant again. 15 min.

11. Story Time: “Feeding 5,000 People”

Conclude story time. “What a miracle that Jesus fed 5,000 people with this food. Let’s remember always to thank God before we eat and to be ready to share with those who are hungry.”

12. Dismissal.

10 min.

Lesson 16: Jesus Taught Us How to Live

Key Concepts

1. God wants us to help others.
2. God wants us to be kind to others.
3. God wants us to love our neighbors as much as we love ourselves.

Objectives

During this session, students will

1. Listen to and discuss the story about a woman who needs help.
2. Hear the Parable of The Good Samaritan.
3. Define the words “good neighbor.”
4. Discuss a series of pictures that represent kind deeds.
5. Explain the term “Armenian miniature.”
6. Add features to the miniature of the Good Samaritan.

Materials Needed

1. On the display table, prop open the *Jesus* storybook to the page of the Good Samaritan; paper bag of groceries; book of Armenian miniatures.
2. Crayons or pastel markers.
3. A Children’s Bible.

Procedure

1. Welcome children warmly and direct them to the display table. Discuss. If children ask about the groceries, explain that they’ll be hearing a story today about someone who has to carry a heavy bag of groceries and needed help, etc.
2. Stand to say the opening prayer together. 5 min.
3. Read *Our Life Together*. Ask the children why Michael’s father could be proud of him.
4. Now read the story of the Good Samaritan from your children’s Bible as directed in *God’s Word to Us*
Ask: “Who was the good neighbor? Why do you think so?” 15 min.
5. Read *We Learn About God*. Discuss each drawing and conclude whether or not there is an act of kindness or thoughtfulness being portrayed. Put a smiley face under or next to the drawing if there is. For drawing #4, encourage the children to discuss what is happening in the picture. Ask: “What do you think the boy just watching should do? Should he help him or should he join the other children and laugh at him? What would you do?” 10 min.
6. Snack. 10 min.

7. Read *Our Armenian Way*. Point out the Armenian miniature-style illustration of the Good Samaritan. “This is similar to the drawings the monks made a long time ago.”
8. Say: “We are going to color in certain parts of our Good Samaritan miniature. You decide – if it is a sunny day, color the sky blue and put a sun in the sky. If it is a cloudy day, color your sky dark blue with gray clouds. Color the donkey gray or brown. Color the man who is hurt.” 10 min.
9. Story Time: “Jesus Shines Like The Sun”
Conclude story time: “Jesus was shining with the glory of God. Sometimes we can feel like this when we are doing what God wants us to do.”
10. Dismissal. 10 min.

Lesson 17: Jesus Taught Us How to Pray

Key Concepts

1. Jesus taught the disciples how to pray.
2. Prayer is talking with God.
3. There are many kinds of prayer.

Objectives

During this session, students will

1. Examine the display table.
2. Listen to a story about helping others.
3. Learn that Jesus taught the disciples the Hayr Mer prayer.
4. Recognize that Jesus also prayed to God the Father.
5. Discover that there are many different kinds of prayer.
6. Recite the first two lines of the Lord’s Prayer.
7. Make a Hayr Mer mobile.

Materials Needed

1. On the display table, place the picture of Jesus at prayer from the day’s lesson; items that relate to “kinds of prayer” under *We Learn About God*: a small pillow (bed), a map (a trip), a plastic hamburger (eat), a sun (morning). Hang a completed Hayr Mer mobile in the classroom.
2. Prepared figures of Jesus and prayer cards – a set for each child (see #3 directly underneath); hole punch; ribbon or string; crayons or colored pencils. You may need parent help to prepare for this lesson.
3. For Hayr Mer mobile and prayer cards: Reproduce Jesus pattern on card stock, affixing front to back; punch a hole in the top center of his halo. Copy the prayer cards (also on card stock); punch a hole at the top of each and put ribbon through so they are ready to hang.
4. A Children’s Bible.

Procedure

1. Welcome children warmly and direct them to the display table.
2. Stand to say the opening prayer together. 10 min.
3. Direct the children to the story corner. Read *Our Life Together*. At the end of the story, say, “What

are the children planning to do? (Prompt them with suggestions for ways kindergarteners can raise money: selling homemade cards, doing chores at home, etc.) Do you think God will be pleased?"

5 min.

4. Say: "Let's turn to the page where you will see a picture of Jesus praying." Read *God's Word to Us*. As you read the Lord's Prayer in English, stop at the end of certain sentences to paraphrase the words and clarify meaning. Discuss.
5. Read *We Learn About God*. Discuss each type of prayer, referring back to the display table. 10 min.
6. Snack. 10 min.
7. Review *Our Armenian Way* with the children. Say: "Only the beginning of the Lord's Prayer appears here. I will read it to you. Please stand and hold your hands in a prayer position."
8. Say: "We are going to make a Hayr Mer mobile (*show completed mobile*). A mobile is something that hangs and has moving parts. And since it's fun to look at, this will help us remember our prayer. Just as Jesus taught this prayer to his disciples, I am going to teach it to you. Repeat after me – "Hayr Mer vor hergins yes, soorp yeghitzi anoon ko. This means Our Father who art in heaven, hallowed be thy name." Repeat several times.
9. Place a figure of Jesus in front of each child. Say: "I want you to color Jesus' beard and his robe." As each child finishes, attach a ribbon/string at the top of the figure. An assistant can help them attach the prayer cards to his hands, first punching a hole in each. When all the mobiles are completed, review the words: "Our Father who art in heaven, hallowed be thy name. Hayr Mer vor hergins yes, soorp yeghitzi anoon ko." 15 min.
10. Story Time: "Lost Sheep"
Conclude story time: "Look how precious all these things were to the people in Jesus' story: the shepherd, the woman and the father. This is how precious each one of us is to God!"
11. Dismissal. 10 min.

Lesson 18: Jesus Taught Us Who He Was

Key Concepts

1. Jesus loved to tell stories.
2. Jesus is always with us.

Objectives

During this session, students will

1. Examine the display table.
2. Listen to a story about little Jack caught in a rainstorm.
3. Hear the story of how Jesus calmed a storm.
4. Compare the feelings of Jack and those of the disciples.
5. Learn about the Armenian blessing of the water service or *Churorhnek*.
6. Make a boat and retell the story of the storm.

Materials Needed

1. On the display table, place magazine pictures of storms; toy boats; a small bowl of water; a cross; the boat that the children will make as part of today's lesson.
2. Pre-prepared brown (3½" x 6") paper boats and white (3" x 4") paper sails; straws; craft sticks - one for each child; scissors; masking tape; crayons. You may want to ask for parent help to prepare the pieces for the boat and sail (see Appendix) and to help children during the lesson.
3. A Children's Bible.

Procedure

1. Welcome children warmly and direct them to the display table.
2. Stand to say the opening prayer together. 10 min.
3. Move to the story corner and read from *Our Life Together*, directing children's attention to the picture of the boy walking alone. When you finish, engage the children in a discussion of Jack's feelings. Ask: "Why was Jack happy to see his mother at the end of the path?"
4. "Look at the picture of Jesus calming a storm." Read *God's Word to Us*. Begin a discussion of the similar feelings which Jack and the disciples had, for example: fear, worry, joy at seeing his mother, joy when they saw Jesus calming the sea. 10 min.
5. Read *We Learn About God*. Have children respond to questions, perhaps even imitating the sounds described. Remind the children that Jesus is always with us, to help us and to keep us safe. 5 min.
6. Snack. 10 min.
7. Read *Our Armenian Way*. Review with the children the story they already know about Jesus' baptism. Allow them to tell as much of the story as they can. Then make the connection that just as God blessed his son as Jesus came up out of the River Jordan, so the Church blesses water, to remind us of that day and the power of God. "Now back to our storm!"
8. Tell the children: "We are going to make a boat to help us when we retell the story of Jesus and the storm." Give each child the half circles of brown construction paper. Next have them tape a straw mast on the back of each ship. Then give each child their sail (see diagram). Say: "This will be the sail for your boat. Color stripes on it." (Illustrate what you mean by stripes.) Have children attach the sail to the straw mast with masking tape. 10 min.
The last piece to be attached is the craft stick that should be taped to the lower portion of the boat allowing the child to hold it to enable movement during the storm. Move to a part of the room where you can begin retelling the story of the storm. The children can manipulate their boats at the appropriate times during the story. 5 min.
9. Story time: "Only One Says Thank You"
Conclude story time: "Jesus was amazed that only one person stopped to thank God for the wonderful thing that had happened to him. Let's not be like the other nine! Let's always remember to thank God for everything."
10. Dismissal. 10 min.

Lesson 19: Jesus Made People Feel Better

Key Concepts

1. Effective prayer and good works come from true faith.
2. We can pray for people we know and those we do not know.

Objectives

During this session, students will

1. Examine the display table.
2. Listen to a story about a lonely woman and how a group of children helped to make her feel happy.
3. Listen to a Bible story in which Jesus heals a small boy.
4. Explore the connection between faith and prayer and good works.
5. Recall that they can and should pray for others.
6. Listen to a prayer based on the litany for the sick.
7. Make a card to send to someone who is sick or lonely.

Materials Needed

1. On the display table, place get well cards; an empty pill bottle; a mustard seed glued on a sheet of white paper and a hand magnifier.
2. Construction paper of different colors (8½" x 11") to make cards; mustard seeds; glue; copies of the Scripture quote (see Appendix) for each child; markers; crayons. Mustard seeds can be obtained from a market.
3. A Children's Bible.

Procedure

1. Welcome the children warmly and direct them to the display table.
2. Stand to say the opening prayer. 10 min.
3. Move to the story corner. Say, "Today's story is about a group of children, just like you, who helped make a lonely woman happy again." Read from *Our Life Together*. Ask, "What made Mrs. Kaloustian happy?" Discuss visits the children may have made to nursing homes, relatives, etc.
4. Begin to read *God's Word to Us*. Remind the children of what they looked at on the display table. Say, "Boys and girls, what you saw under the magnifying glass was a mustard seed. Jesus tells us that if we believe in him -- even this much -- he will always be with us." Distribute crayons and ask children to put a dot in the square space on the page. "That is the size of a mustard seed." 10 min.
5. Ask the children, before reading *We Learn About God*, "Can we pray for other people?" Ask the children to explain what the girl in the picture is doing (praying, of course). "Who might she be praying for?"
6. Discuss the questions. 10 min.
7. Snack. 10 min.
8. Say: "In your lesson, look at the page where you will see a prayer with a beautiful border around it." Read *Our Armenian Way*. Read and discuss the prayer for the sick.
9. Review with the children the words Jesus said about faith. Say "Today, you will make a card to send to someone who is sick or lonely." On the table, place the construction paper and the quote

by Jesus. Say: "Choose a piece of colored paper. Fold it carefully." Show the children how to fold their papers. Say: "On the cover of your card, I want you to glue a mustard seed." Give each child a mustard seed. Say: "Inside the card, I want you to glue the words Jesus' said about having faith." Discuss the quote with the children as well as who the recipients will be. Attach note to parents as to who should be given the card; if there is no one the child can identify, ask child if the card can be shared with a homebound parishioner, a nursing home resident, etc. 10 min.

10. Story time: "Now I Can See Him"

Conclude story time. "Jesus came to help us learn how to be better people, to follow God's ways. He is always so happy when we do!"

11. Dismissal.

10 min.

Lesson 20: Jesus Taught Us How to be Together

Key Concepts

1. We are all part of God's family.
2. The Lord is always with us when we gather in his name.

Objectives

During this session, students will

1. Examine the display table.
 2. Identify some of the biblical concepts of community known as the "one anothers."
 3. Hear the purpose of the Kiss of Peace.
 4. Recite the Kiss of Peace.
 5. Practice the passing of the Kiss of Peace.
 6. Attend church during the Kiss of Peace.*
 7. Participate in a discussion about friends and friendship.
 8. Discuss the things we do when we come together at church.
- * Arrange to get to church for a 15-minute period to participate in the Kiss of Peace.

Materials Needed

1. On the display table, open the student text to the photo of the passing of the Kiss of Peace; pictures of some Armenian churches in America.
2. A Children's Bible.

Procedure

1. Welcome children warmly and direct them to the display table.
2. Stand to say the opening prayer together. 5 min.
3. Jump right to page 3 of today's lesson: Read *We Learn About God*. Explain God's wish that we come together as a church family and that one of the things we do when we come together is *care* for one another. Say: "When we are in church, we recite something together called the Kiss of Peace. When we say the words of the Kiss of Peace, we are saying to each other: 'God wants us to be a family, filled with peace and love.' Now let's look together at the picture of two people in church exchanging the Kiss of Peace." Read *We Celebrate*. Review the Kiss of Peace greeting with the children: "Christ is revealed among us. Blessed is the revelation of Christ." Or: "Krisdos ee mech mer haydnetzav. Orhnyal eh haydnoutiounun Krisdosee."

4. Move to another part of the room to practice the Kiss of Peace. The children should stand side by side as if in a pew. Teach the placing of the right hand on the heart. Demonstrate the exchanging of the Kiss of Peace with an assistant or a child. Then say, “Now you try it. I will help you.” 15 min
5. Go to church to participate in the actual Kiss of Peace. 15 min.
6. Snack. 5 min.
7. Tell the children to go to the story corner. Direct their attention to the two children shoveling snow. Read *Our Life Together*. Ask the children, “Was Sarah’s friend a good friend? What does it mean to be a good friend?” Discuss.
8. Point to the illustration of the grandfather and child. Ask: “What do you think they are talking about?” Read *God’s Word To Us*. Conclude with the observation: “It’s so nice, isn’t it, when we spend time with our families. God is so happy when we do!”
9. Point to the different pictures of Armenian churches in America. What do they notice (crosses, domes, etc.)? Read *Our Armenian Way*. Then ask children: “What are some of the things we do when we come to church?” (pray, sing, Sunday School, learn, etc.) 10 min.
10. Story Time: “Heaven Belongs to Them”
Conclude story time: “Isn’t it great to know that Jesus has a special place in his heart for you? Let’s remember that all week.”
11. Dismissal. 10 min.

Lesson 21: Jesus Taught Us to Share Our Faith

Key Concepts

1. God wants us to witness to our faith through words.
2. God wants us to witness to our faith through action.

Objectives

During this session, students will

1. Examine the display table.
2. Listen to a story about two boys who share their faith.
3. Describe what happened at the Feast of Pentecost.
4. Retell, with help, what happens during the Last Blessing and Dismissal.
5. Recite “I will bless the Lord...”
6. Decorate a Gospel Book cover.
7. Attend church service and, if possible, participate in the Last Blessing and Dismissal.

Materials Needed

1. On the display table prop up the lesson page picture of the Last Blessing and Dismissal and the photo of the Gospel Book; an actual silver-or-gold-plated Gospel Book or Bible (if possible); a decorated cardboard Gospel Book cover already completed.

2. Cardboard pieces (8½" X 11" or any convenient dimension), in different colors, one for each child; flat jeweled beads(easy to glue); foil; pens; glue; clear tape; paper plates.
3. A Children’s Bible.

Procedure

1. Welcome children warmly and direct them to the display table. Recite the opening prayer together.
2. Move to the story corner. Discuss the picture of the two boys in church and ask, “What do you think is happening here?” Read the story from *Our Life Together*. 5 min.
3. Read *God’s Word To Us* and *We Learn About God*. Discuss the Scripture with the children. Ask: “What do you think this wind might have sounded like? What did the flames of fire feel like? How would you have felt to see tongues of fire over your friends’ heads? Etc. At the end, repeat: “Thaddeus and Bartholomew were the two disciples sent to Armenia.” 5 min.
4. Direct children to their lesson page featuring the photo of the Last Blessing. Read *Our Armenian Way*. Help the children learn the Psalm verse that is sung during the Last Blessing and Dismissal (“Orhnetzitz uzDer...”): “I will bless the Lord at all times; at all times his praise shall be in my mouth.” (Psalm 34:1) 5 min.
5. Snack. 5 min.
6. Hold up the decorated Gospel Book cover from the display table. “This is something like the beautiful Gospel Book or *Avedaran* we see on the altar.” And/or you can hold up the real thing, if you were able to obtain one. Read from *We Celebrate*.
7. Say: “Now you are going to make your own very special Gospel Book cover. Let’s look very closely at the picture we saw of the Gospel Book. Notice how the cover is decorated.” Ask children to help give out the cardboard pieces (one for each child). Give each child a sheet of aluminum foil. Demonstrate how to use the foil to cover the cardboard. Use tape to hold the edges. Help them draw a large cross in the center. Place a paper plate of beads in front of each child. Encourage the children to lay out the beads on the cover before applying glue. 15 min.
8. Story time: “Lazarus, Come Out”
Conclude story time: “Jesus loved his friend Lazarus so much, he brought him back from the dead. He loves us so much that we, too, will live forever after we die!” 10 min.
9. If there is time to attend church, take the children to see the Last Blessing and Dismissal and to kiss the Gospel Book.
10. Dismissal from church. 15 min.

Lesson 22: We Join the Church with Baptism

Key Concepts

1. Through baptism we become children of God.
2. Through chrismation our baptism is sealed.

Objectives

During this session, students will

1. Examine the display table.
2. Hear a story about a Sunday School class visiting the baptistry with Der Hayr.
3. Listen to a Bible passage about Jesus' baptism.
4. Participate in a story about making good choices.
5. Demonstrate the blessings of chrismation.
6. Make a dove as a reminder of the Holy Spirit.

Materials Needed

1. On the display table, put pictures of Jesus' baptism and/or a child's baptism; a dove-shaped muron container (if one can be borrowed); a doll; a small bottle of baby oil.
2. A Children's Bible.

Procedure

1. Welcome children warmly and direct them to the display table. Encourage them to look closely at the objects on the table.
2. Stand to recite the opening prayer. 5 min.
3. Move to the story corner and direct children's attention to the photo of muron-blessing in Etchmiadzin. Read from *Our Life Together*. Say: "What did Harout remember about his sister's baptism?" (Der Hayr said that when we are baptized we become a child of God. We become a member of God's family.) 5 min.
4. Read *God's Word to Us*. This has already become a familiar story to Kindergarteners.
5. Now read from *We Learn About God*. Ask the children, "What are some good choices we can make?" (These can be as simple as: waiting one's turn, holding the door open for someone, throwing a gum wrapper into the trash and not on the floor, bringing in cans for a food drive.) 10 min.
6. Snack. 10 min.
7. Direct children's attention to the picture of a priest anointing a baby (chrismation). Read *Our Armenian Way*. Using the doll and the baby oil, demonstrate the way the priest blesses the nine parts of the baby's body, by dipping the tip of your thumb into the oil and tracing a cross on each part. Recite the blessings as you do. Children can role play being godparents and holding the baby. 5 min.
8. Read *We Celebrate*. Then, before reading the story again, say: "We're going to make a dove out of paper to remind us of the one made out of silver that the priest uses. It will also remind us of the blessing with Holy Oil of the nine parts of a baby's body. Give each child the two strips of paper as indicated on the diagram. Ask them to fringe one end of each strip. (This will be difficult for some because of a lack of fine motor coordination.) Have them bring both strips to you or an aide. Print their names on one strip, then staple the unfringed ends together. Push the top strip forward to form a head; place a staple there. Now push the bottom strip forward to form the body of the dove (both strips should now be fairly equal); staple. Now staple one end of the elastic band where the head was stapled. Now have children stand, reread *We Celebrate*, and ask them to recite God's words with you, "This is my Son. I am pleased with him." At these words, the children can "fly" the doves. 15 min.

9. Story Time: “Jesus Is Welcomed Like A King”

Conclude story time: “Jesus was welcomed into Jerusalem like a king, and in the temple he was still teaching the people the right way to live. We can live the right way by following Jesus, too.”

10. Dismissal.

10 min.

Lesson 23: We Grow in Faith Together

Key Concepts

1. Jesus, Mary and Joseph worshipped as a family.
2. When we attend church, all of us become a community of the faithful.

Objectives

During this session, students will

1. Examine the display table.
2. Listen to and discuss a story about a curious child named Helen.
3. Explore questions about Bible stories and nature.
4. Listen to a Bible reading about the early religious experiences of Jesus.
5. Compare their life experiences with those of Jesus.
6. Explain what happened on the eighth and fortieth days in the life of Jesus.
7. Identify specific Armenian traditions of *Dyarnuntarach*.
8. Color and decorate a traditional picture of the Presentation.

Materials Needed

1. On the display table have a variety of illustrated Bible story books, including the *Jesus* reader, as well as a few “I Wonder Why”-type picture books from a local library on various topics, such as whales, weather, rocks, etc. – at least one for each child.
2. “Presentation” coloring picture (one for each child) mounted on cardboard; colored pencils; crayons; glue sticks; glitter. Use gold for baby Jesus’ halo; silver for the others.
3. A Children’s Bible.

Procedure

1. Welcome children warmly and direct them to the display table. Encourage them to look at the books.
2. Ask the children to stand for the opening prayer. 5 min.
3. Go to the story corner. Say: “Look at the picture of a girl raising her hand.” Read from *Our Life Together*. Ask: “Do you like to ask questions? Why do you ask questions? What are some questions you have right now, about anything?” Discuss. 5 min.
4. Distribute library books and have children look through them. After a few minutes, ask each child to hold up their book and pose any questions they had while looking through the books. 10 min.
5. Read *God’s Word To Us*. Direct children’s attention to the miniature-style illustration of the Presentation. Describe the picture: Mary is presenting the baby Jesus to the Temple priest Simeon. Behind him is Joseph, and behind Mary is the prophetess Anna. Both Simeon and Anna had been waiting a long time to see this special baby.

Review with the children the different periods in Jesus' early life when he was taken to the temple and for what purpose (eighth day to be named, fortieth day to be 'given' to the Lord, age 12 for the celebration of a feast, Passover). 5 min.

6. Read *We Learn About God*. Engage the students in a discussion of the questions, to find similarities between Jesus and themselves. 5 min.

7. Snack. 5 min.

8. Read *Our Armenian Way* and *We Celebrate*.

9. Tell children that they will color a picture of *Dyarnuntarach*. Distribute mounted pictures, colored pencils, crayons, glue, and glitter. Use this time as an opportunity to review the story. 15 min.

10. Story Time: "The Ten Girls With Oil Lamps"
Conclude story time by asking, "What are some ways we can let God know who we are?" (doing good things, praying, coming to church with our families, etc.)

11. Dismissal. 10 min.

Lesson 24: We Remember Jesus on Sunday

Key Concept

1. The Last Supper is remembered during the Holy Badarak.

Objectives

During this session, students will

1. Examine the display table.
2. Review how *nushkhar* (communion wafer) is made.
3. Review the story of the Last Supper.
4. Discuss the meaning of "breaking bread."
5. Identify the Great Entrance.
6. Make a chalice.
7. Attend Holy Badarak to observe the Great Entrance and/or to take Holy Communion with their families.

Optional: Arrange with your pastor to have a nushkhar-making session with the children.

Materials Needed

1. On the display table place a Divine Liturgy book which has pictures. If you can, locate a book of ancient Armenian art treasures; look for an ornate picture of a chalice - a replica of one, available from religious supply websites, would be wonderful; a wooden stamp for imprinting the *nushkhar* (borrow this from your pastor); a pita bread; a small jar of "wine" (grape or cranberry juice).
2. Bread (for breaking bread); glue; markers; scissors; pre-cut chalices on dark yellow or gold-colored paper, yellow and white construction paper, plastic lids (two different sizes) to be used by the children as templates for tracing a paten (light yellow paper) and a *nushkhar* (white paper); sheets of dark purple or green construction paper on which to mount chalices and patens.

3. Ask your pastor for a *nushkhar* for each child in your class.
4. A Children's Bible.

Procedure

1. Welcome children warmly and direct them to the display table. Talk with them about objects and pictures.
2. Stand for the opening prayer. 5 min.
3. Go to the story corner. Say: "Look at the picture of the priest making *nushkhar*." Read and discuss *Our Life Together*, *God's Word To Us* and *We Learn About God*. 10 min.
4. Review material in *Our Armenian Way* and *We Celebrate*; hold up and pass around an actual chalice, if possible. Arrange to attend church for the children to see the Entrance. 15 min.
5. Snack. 5 min.
6. Upon returning from church, have children look at the pictures of the Great Entrance. "We are going to make a chalice, a paten and a *nushkhar*. The paten is the little dish that is placed over the chalice. Then the *nushkhar* is placed on the paten, and everything is covered with a cloth until Der Hayr is ready to use it.
 "I am going to give you a chalice cut from yellow paper. We will pretend it is gold." On the table put yellow and white construction paper. Also put some plastic lids of different sizes for the paten and the *nushkhar*. Have children trace and cut a round circle out of yellow paper, to be used as the round dish (paten), then a smaller white circle for the *nushkhar*. When they have finished cutting, instruct them to draw a cross on the round white *nushkhar* and then decorate the chalice with markers. Say: "When you are finished with all three pieces, I want you to glue them on a piece of paper. First, glue the chalice; next to it the paten and then the *nushkhar*. Bring the finished papers to me, and I will print the names under each one." 15 min.
7. Story Time: "A Special Night"
 Conclude story time: "Jesus made it possible for all his disciples to teach others about him. How can we share the good news of Jesus?" (most importantly, by showing others our faith through everything we say and do)
8. Dismissal. 10 min.

Lesson 25: We Honor Jesus in Church with Words and Actions

Key Concept

1. We honor Jesus by our words and actions.

Objectives

During this session, students will

1. Examine the display table.
2. Listen to a story about ways to honor Jesus in our daily actions.
3. Hear St. Paul's words about being part of God's family.

4. Describe what they see, smell and hear in church.
5. Explain the duties of a deacon.
6. Make a deacon's stole.
7. Explain how to wear it.

Materials Needed

1. On the display table, place an authentic deacon's stole (borrow it from church).
2. Make arrangements for a deacon to visit your class briefly to show how he is dressed for church and explain his training and what he does on the altar.
3. Scissors; crayons; small safety pins; pre-cut gold-colored crosses two per child (5" long; if desired, adapt the pattern for lesson 26); pre-cut stoles from brown wrapping paper (3" x 36"); glue. You may need an assistant for this project.
4. A Children's Bible.

Procedure

1. Welcome children warmly and direct them to the display table. If the children want to try on the deacon's stole, let them.
2. Stand for the opening prayer. 10 min.
3. Go to the story corner. Direct children's attention to the picture of the family in a van. Read from *Our Life Together*. Ask: "Does someone say, 'Bless you' when you sneeze?" Discuss the ways the people in the story stopped and prayed and explore ways the children do or can.
4. Direct children's attention to the photo of the historic Armenian church. Read and explain *God's Word To Us*.
5. Now read *We Learn About God*. Then discuss the questions. 10 min.
6. Snack. 10 min.
7. Read from *Our Armenian Way*. Then introduce your deacon who can explain his training and what he does on the altar. 5 min.
8. Get the stole from the display table and turn children's attention to the picture of the deacon receiving his stole from the Bishop. Read *We Celebrate*. The deacon wears this as a sign of his love for God and his service to the church. Say: "Today we are going to make a deacon's stole." Distribute a paper strip to each child. Say: "Take a red crayon and color around the edges of the stole. That is called a border." (Demonstrate.)
 Next give each child two pre-cut crosses of yellow and/or gold-colored paper. Before children glue the crosses onto the stole, 1) check to see that crosses are going in the right direction and 2) if the stole is too long (drape it over child's shoulder), cut off a piece at one end.
 When these have been secured, drape the stole over the left shoulder of the child and pin it. 15 min.
9. Story Time: "The Garden of Prayer"
 Conclude story time: "This was the end of a very sad day. Why do you think Peter said he didn't know Jesus? Yes, maybe he was afraid. Have you ever been afraid of something? How did it feel?"
10. Dismissal. 10 min.

Lesson 26: The Cross is a Special Sign

Key Concepts

1. Jesus is in heaven.
2. The cross reminds us of Jesus' love for us.

Objectives

During this session, students will

1. Examine the display table.
2. Listen to a story about two sisters and their discovery.
3. Listen to a Bible passage about Jesus and the cross.
4. Review the story of the empty tomb.
5. Name, with help, the different forms the cross takes in Armenian life.
6. Draw a picture of an Armenian cross.
7. Make an Armenian hand cross out of oak tag.
8. Practice the signing of the cross in Armenian and English.

Materials Needed

1. On the display table place pictures of *khachkars* (see entry for "Cross, Stone" in *Children's Encyclopedia of Armenian Christianity*); pictures of Armenian churches; a picture of an Armenian cross; an actual hand cross (borrow one from your pastor); a sample of the hand cross children will make; a cross on a necklace; a small *khachkar* replica (widely available).
2. Precut oak tag crosses at least 5" long (see template); craft sticks to serve as a handle for the hand cross; thin magic markers; colored jewels with flat backs; glue.
3. A Children's Bible.

Procedure

1. Welcome children warmly and direct them to the display table. Call their attention to the many pictures on the table and, in particular, the many different kinds of crosses.
2. Stand for the opening prayer. 10 min.
3. Go to the story corner. Have children turn to *Our Life Together*. Discuss the distinctive appearance of an Armenian church. Then read the story. 5 min.
4. Say: "In the Bible, it says that Jesus was carrying a very heavy cross. How do you think he must have felt?" Read from *God's Word To Us*.
5. Direct the children's attention to the illustration of two angels standing beside a tomb. Read from *We Learn About God*. Ask: "What did the angels tell the women?" 10 min.
6. Snack. 5 min.
7. Read *Our Armenian Way*. Hold up the various crosses from the display table. Discuss where else the children might see a cross. Have them draw their own Armenian cross in the space provided on their lesson page. 10 min.
8. "And now you are going to make your own hand cross. (Show sample.) Notice at the bottom of the cross there is a handle. This makes it easier for the priest to hold. You will also be able to decorate

your hand cross with colored stones (provide one large and eight smaller stones for each child - one for center, two for each end) and markers.”

9. Give out the oaktag crosses. Say: “First, decorate the front of your cross. Then glue the handle on.” (Take a few minutes before and after the project to practice making the sign of the cross in Armenian and English.) 10 min.
10. Story Time: “The End...And the Beginning”
Conclude story time: “This is the most wonderful story in the whole Bible. This is where we learn how Jesus died but really didn’t, because he rose from the dead and even saw his friends again. Next time, we’ll read about other times he saw his followers again.”
11. Dismissal. 10 min.

Lesson 27: How the Armenians Became a Christian People

Key Concepts

1. Armenia was the first Christian nation.
2. Sts. Thaddeus, Bartholomew and Gregory brought Christianity to Armenia.
3. Gregory, known as St. Gregory the Illuminator, converted the Armenian nation to Christianity.

Objectives

During this session, students will

1. Examine the display table.
2. Listen to a story about a girl named Ruth and her visit to a friend’s church.
3. Name the three people who brought Christianity to Armenia.
4. Describe the ways, according to St. Gregory, we can be holy.
5. Recall, with help, the story of St. Gregory and Armenia’s conversion.
6. Create a pit with Gregory in it.

Materials Needed

1. On the display table have a completed pit; several books about snakes and insects; rubber snakes and spiders if you feel so inclined!
2. Quart milk cartons cut down to a 3" height (you may need to begin gathering the quart milk cartons a few weeks ahead or ask parents to bring them in), strips of paper (3" x 12"); colored construction paper (even scraps are okay) to make bugs and insects; crayons; scissors; stapler.
3. A Children’s Bible.

Procedure

1. Welcome children warmly and direct them to the display table. Call attention to the pit and to the books.
2. Stand for the opening prayer. 10 min.
3. Go to the story corner. Read and discuss *Our Life Together*. 5 min.
4. Say: “Let’s look at the picture of St. Thaddeus walking on a road.” Read *God’s Word To Us*. Say: “Jesus told his disciples ‘Go and teach the people what I have taught you.’” Now read *We Learn About*

- God*; ask children for examples of these and then for other “rules of holy living.” 5 min.
5. Direct children to the picture of Holy Etchmiadzin on the next page. Read *Our Armenian Way*; tell the story in a very animated way and then review the basic facts. 5 min.
6. Snack. 5 min.
7. Read *We Celebrate*. Say: “Each one of you will get the bottom part of a milk carton to make a pit. I am going to give you a strip of paper. Draw stones on it with black and brown crayons. (Demonstrate.) Bring your pit and the strip of paper to me, and I will staple it around the pit. “Next, on scrap paper, draw as many snakes and bugs as you want. Use the books on the display table to give you ideas. Cut them out and put them inside the pit. Cut out the figure of St. Gregory using the heavy black line. Put St. Gregory in the pit when you are finished.” The figure can be bent at the knees and glued to the bottom of the carton or just propped up. 20 min.
8. Story Time: “Jesus Makes A Promise”
Conclude story time: “Jesus gave all his followers hope and joy by meeting them again after he died. Jesus is with us, too, just like he promised, especially when we’re all together!”
9. Dismissal. 10 min.

Lesson 28: The People of God Celebrate

Key Concepts

1. The Feast of the Transfiguration is a major feast of the Armenian Church, celebrated in July.
2. The Feast of Vartavar was a pagan feast.
3. St. Gregory joined the two feasts to be celebrated on the same day.
4. Our year together has come to an end!

Objectives

During this session, students will

1. Examine the display table.
2. Hear the story of a grandmother explaining the Feast of Transfiguration.
3. Listen to a Bible story about the Transfiguration of Jesus.
4. Re-enact the story together.
5. Create a stand-up figure of Jesus in his radiant white clothes.

Materials Needed

1. On the display table, place a spray bottle of water and a rose; a completed figure of the transfigured Jesus.
2. Pre-cut figure of Jesus (see appendix) – one for each child; gold and/or silver glitter; glue; scissors; craft sticks; play dough.
3. A Children’s Bible.

Procedure

1. Welcome children warmly and direct them to the display table.
2. Stand for the opening prayer. 10 min.

3. Go to the story corner. Point to the illustration on the first page and ask students if they can imagine why someone is throwing water on the children. Discuss and then read *Our Life Together*. 5 min.
4. Read through *God's Word To Us*. After one reading, help the children (six volunteers) "perform" the story while you read again. Have children find all the story's characters in the Armenian miniature illustration. Conclude with *We Learn About God*. Impress upon the children that long after this event happened, the church still wants to remember and celebrate. 10 min.
5. Read *Our Armenian Way* and *We Celebrate* (have children identify characters again) and then say: "We are going to make a stand-up figure of Jesus. It will show how he looked on top of that mountain."
6. Ask a child to help you distribute the cutout figures of Jesus. Say: "This is a figure of Jesus Christ. Carefully put some glue on Jesus' belt and halo and then sprinkle glitter on it."
 After the glue dries a bit, write each child's name on a craft stick. Tape the craft stick between the front and back figures of Jesus. The final step will be to place the craft stick in the center of a wad of play dough to help Jesus stand. Take a piece of play dough. Put the craft stick into the play dough to make Jesus stand. At this time review the events that took place at the Transfiguration. 15 min.
7. Have children sit at the table for their last story together.
 Story Time: "The Holy Spirit"
 Conclude story time: "Jesus made it possible for all his disciples to teach others about him. How can we share the good news of Jesus?" (Most importantly, by showing others our faith through everything we say and do and let's remember that all during the summer!) 10 min.
8. Special celebratory snack! 10 min.

Patterns, Templates, and Prayers

Lesson 3

**Let us in peace eat this meal which has
been prepared for us by the Lord.
Blessed is the Lord in His gifts,
Amen.**

*Ja-sha-ges-tzook kha-gha-ghoo-tyamp
uz-ge-ra-goo-rus vor ba-dras-dyal eh
mez ee Dyar-neh.
Orh-nyal eh Der ee bar-keh-vus yoor,
Amen.*

Lesson 5

I pray for all the children
of the world.

I pray for those who are sick.

I pray for those who are hungry.

I pray for children who do
not have a place to live.

Bless them all.

And bless me,
heavenly Father.

Amen.

Lesson 7





LANTERN PATTERN

Place pattern on
folded paper

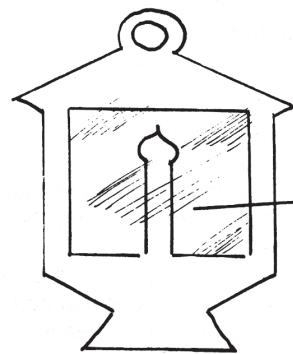
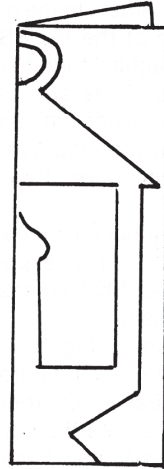
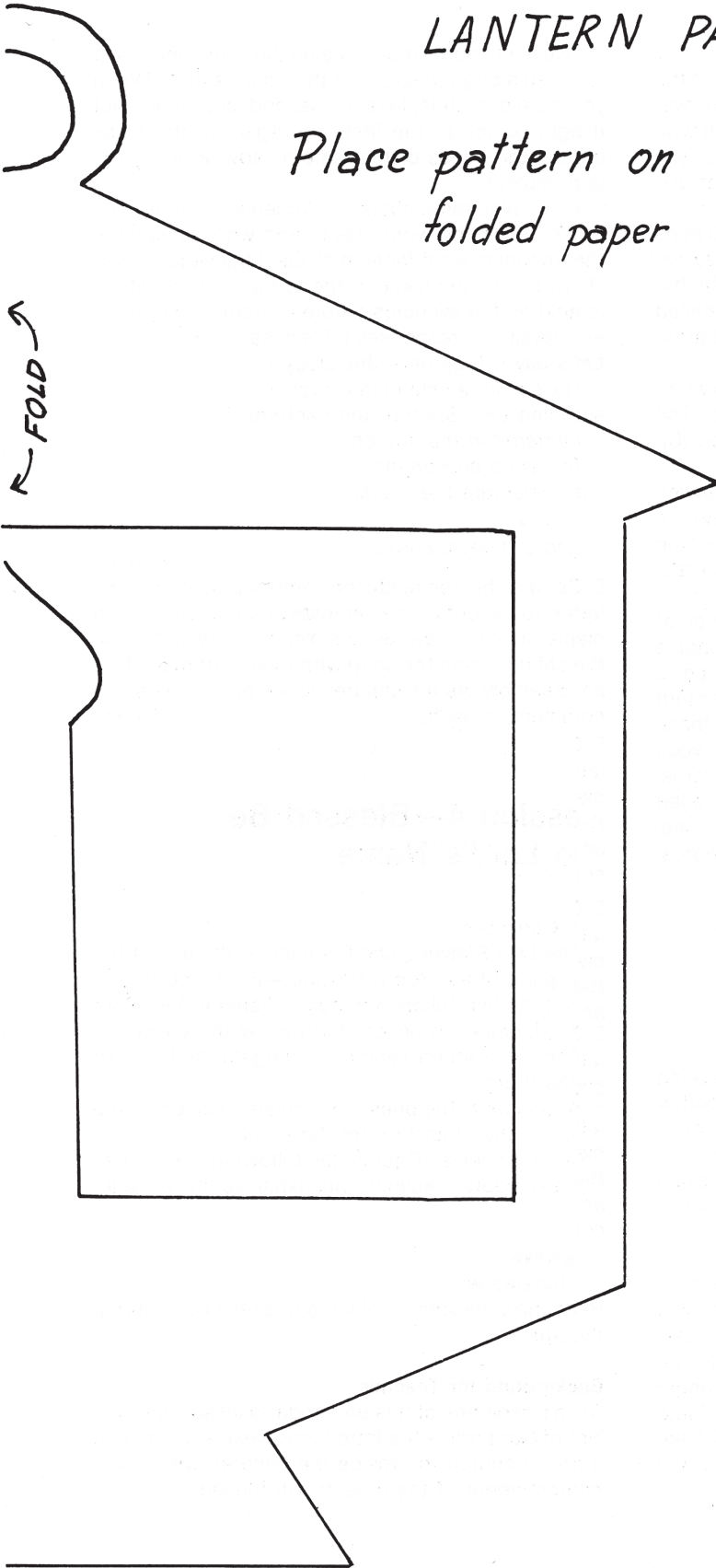

tissue

How to Make a Dove

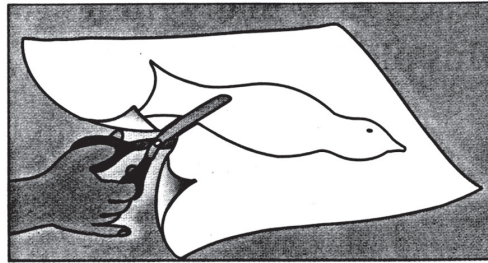

1. Outline a dove on heavy white paper and cut it out.

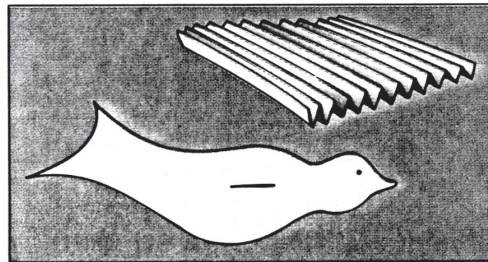

2. Make a slit in the side. Accordion-pleat a sheet of thin white paper.

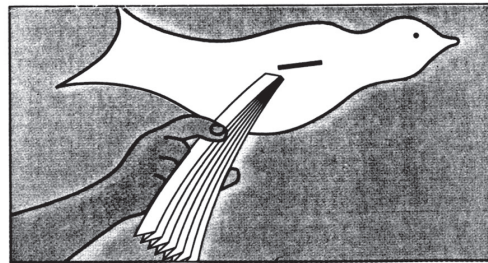

3. Insert the paper into the slit to make wings. To hang, tape wings together and thread string through them.

Lesson 13

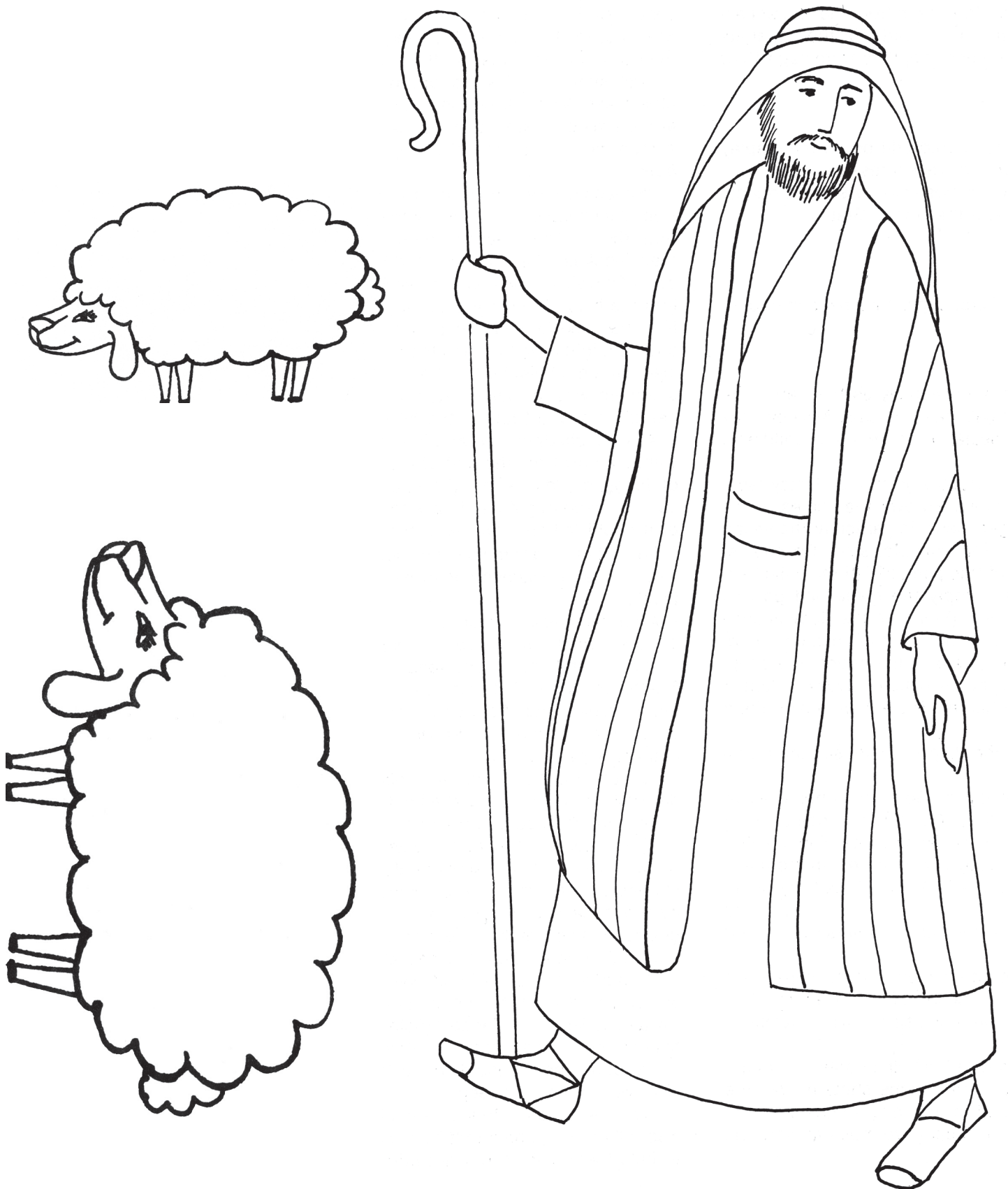



Lesson 14

Guardian Angel, help me to do good things.

Lesson 17

**Hayr Mer
vor hergins yes
soorp yeghitzi
anoon ko.**

**Our Father,
who art in
heaven,
hallowed be
thy name.**



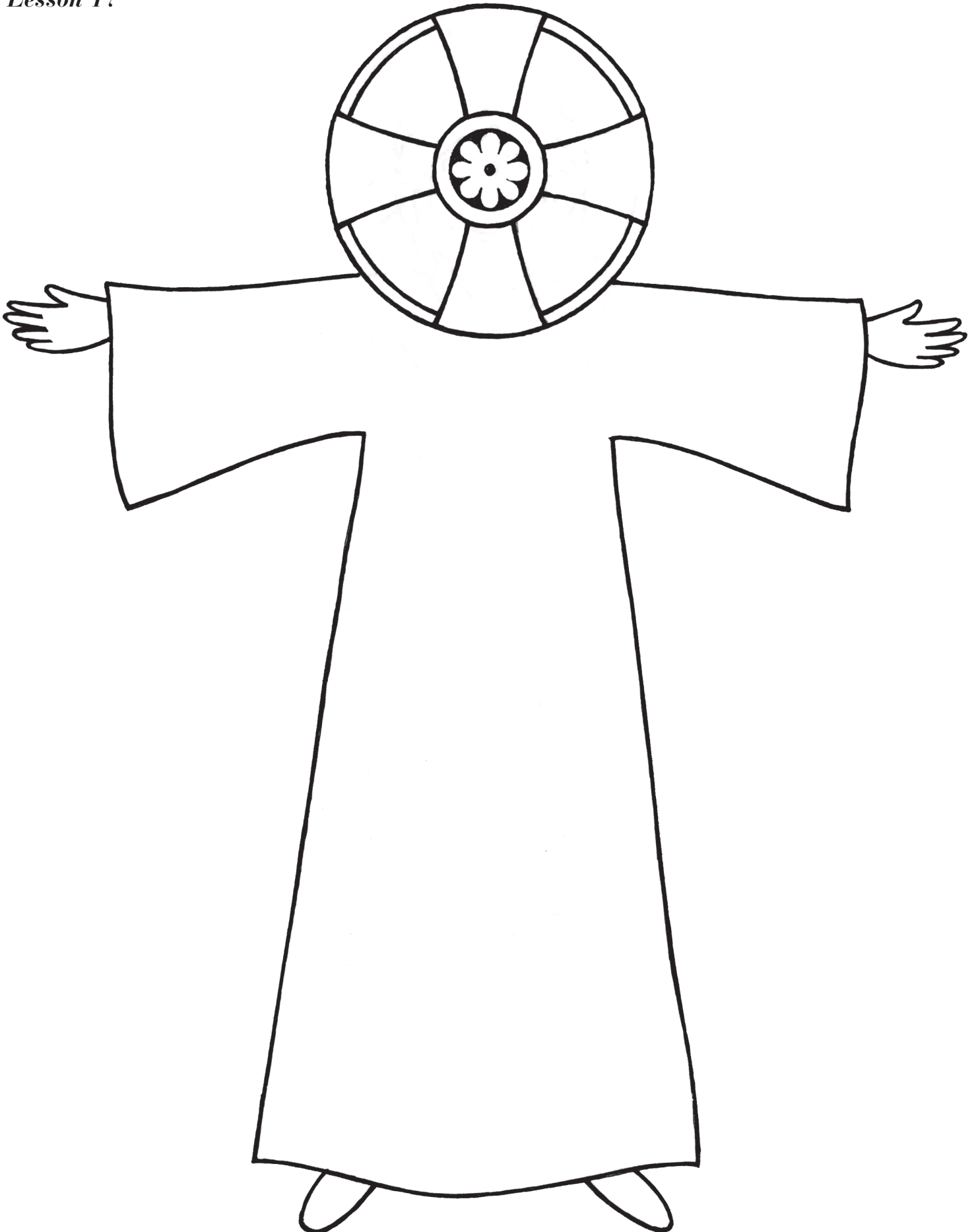

Lesson 18

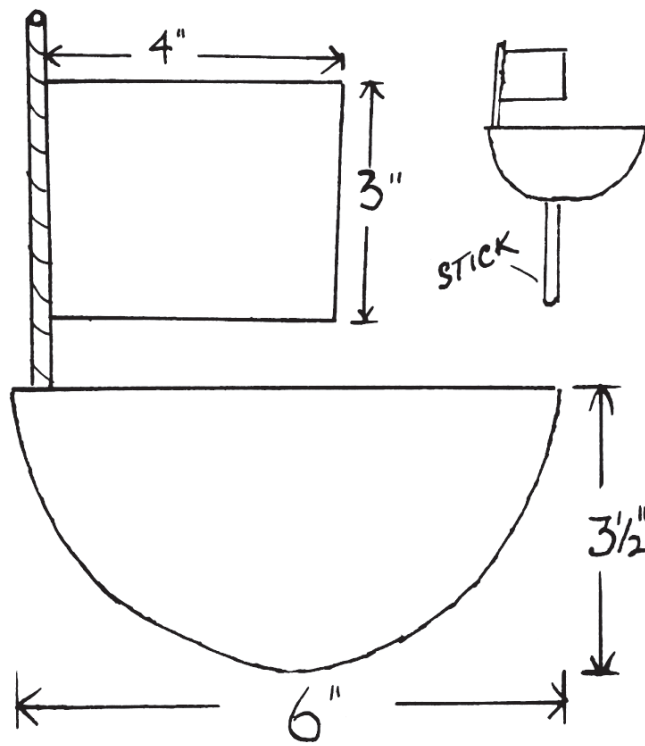

Lesson 19

“Even if you have faith
no larger than
a mustard seed,
I will always be
with you.”

Lesson 22

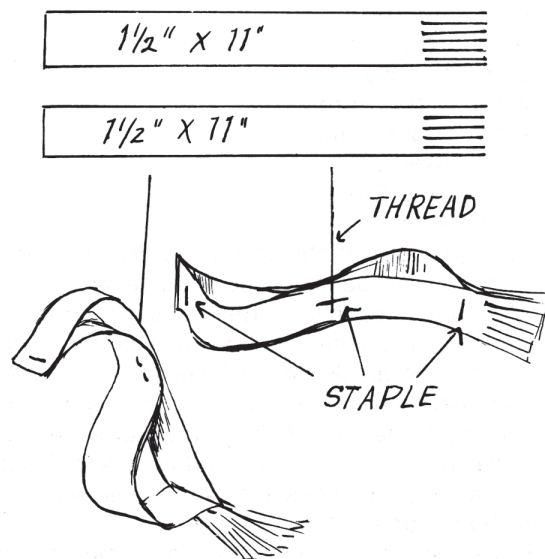



Lesson 24

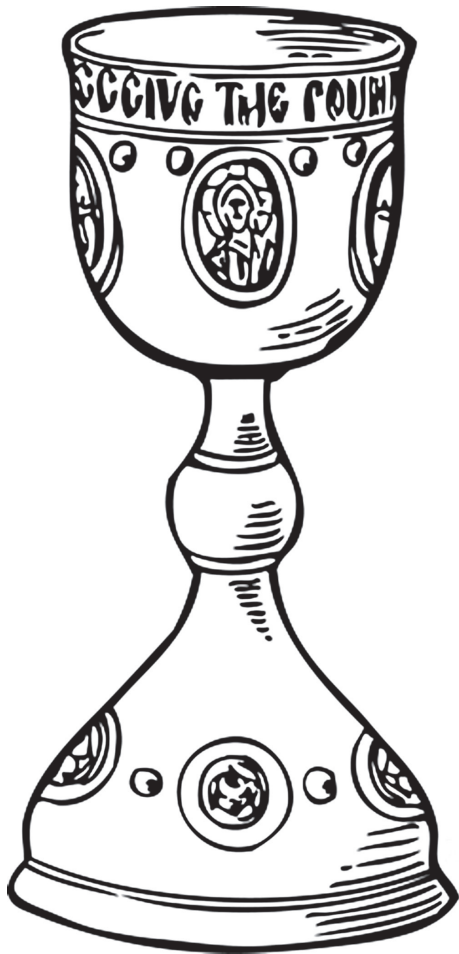

Lesson 26

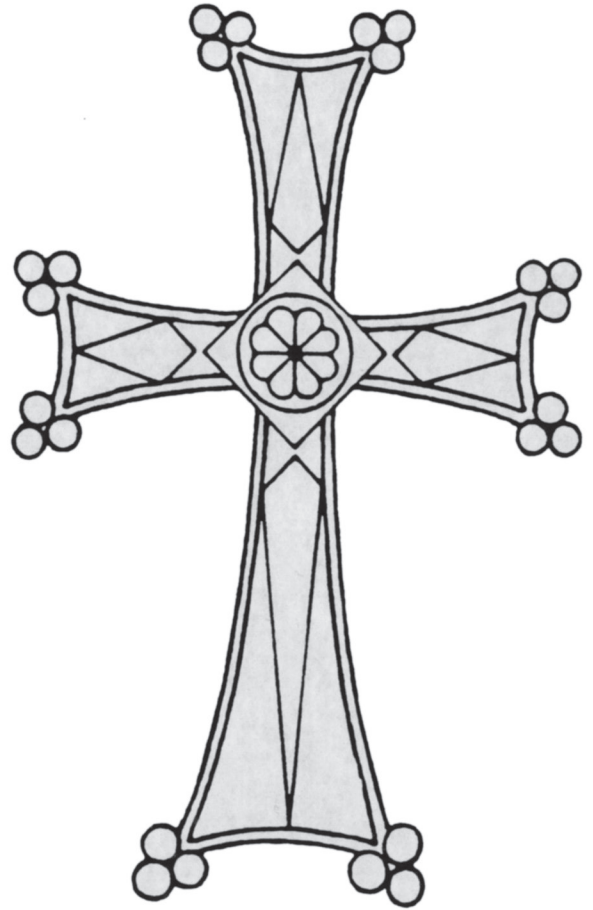

Lesson 27

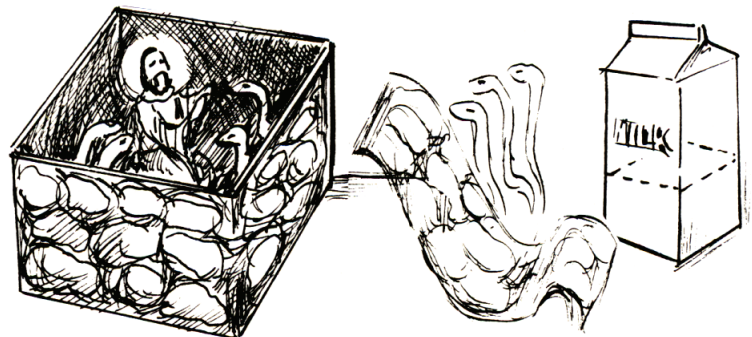

Lesson 28

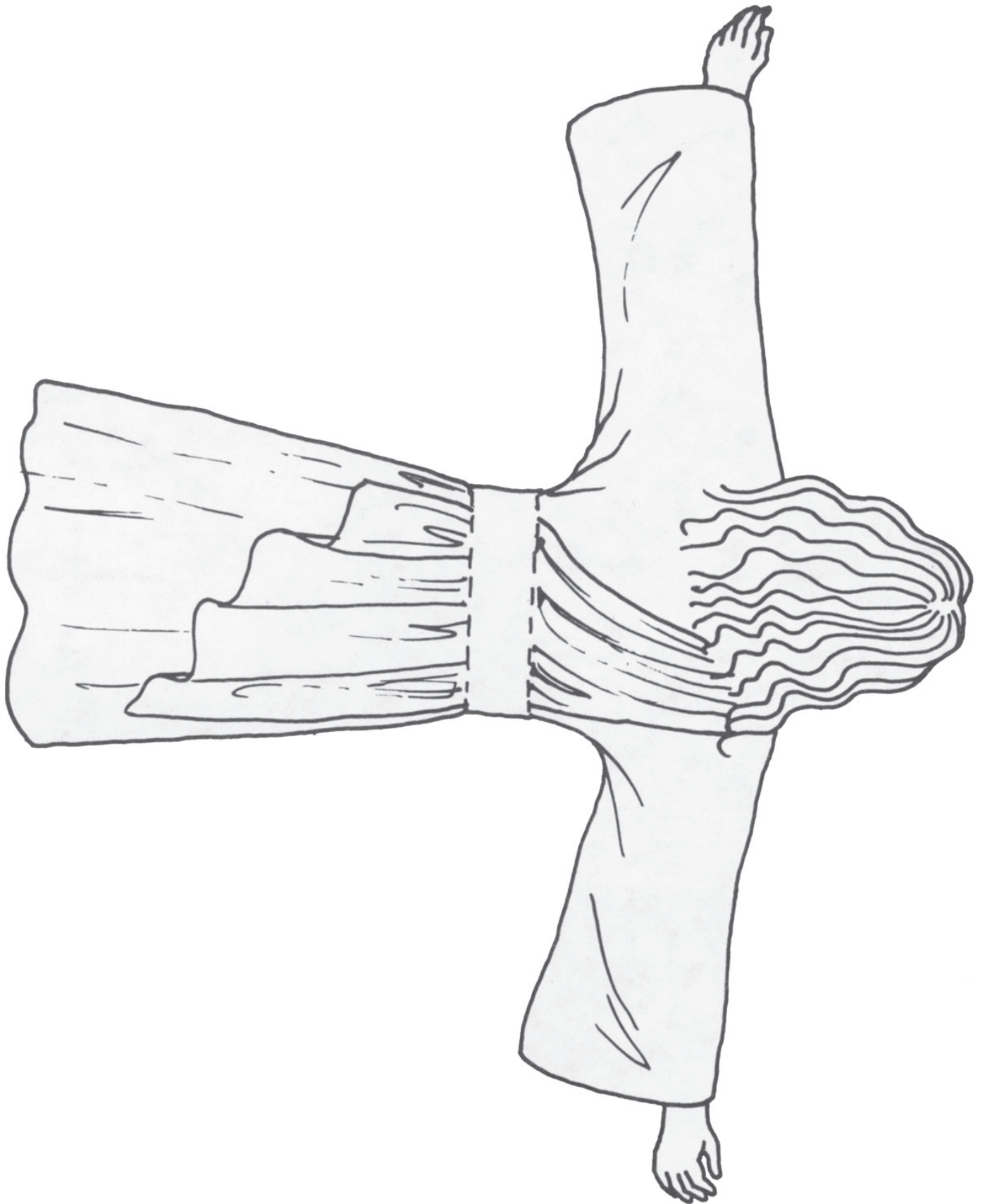

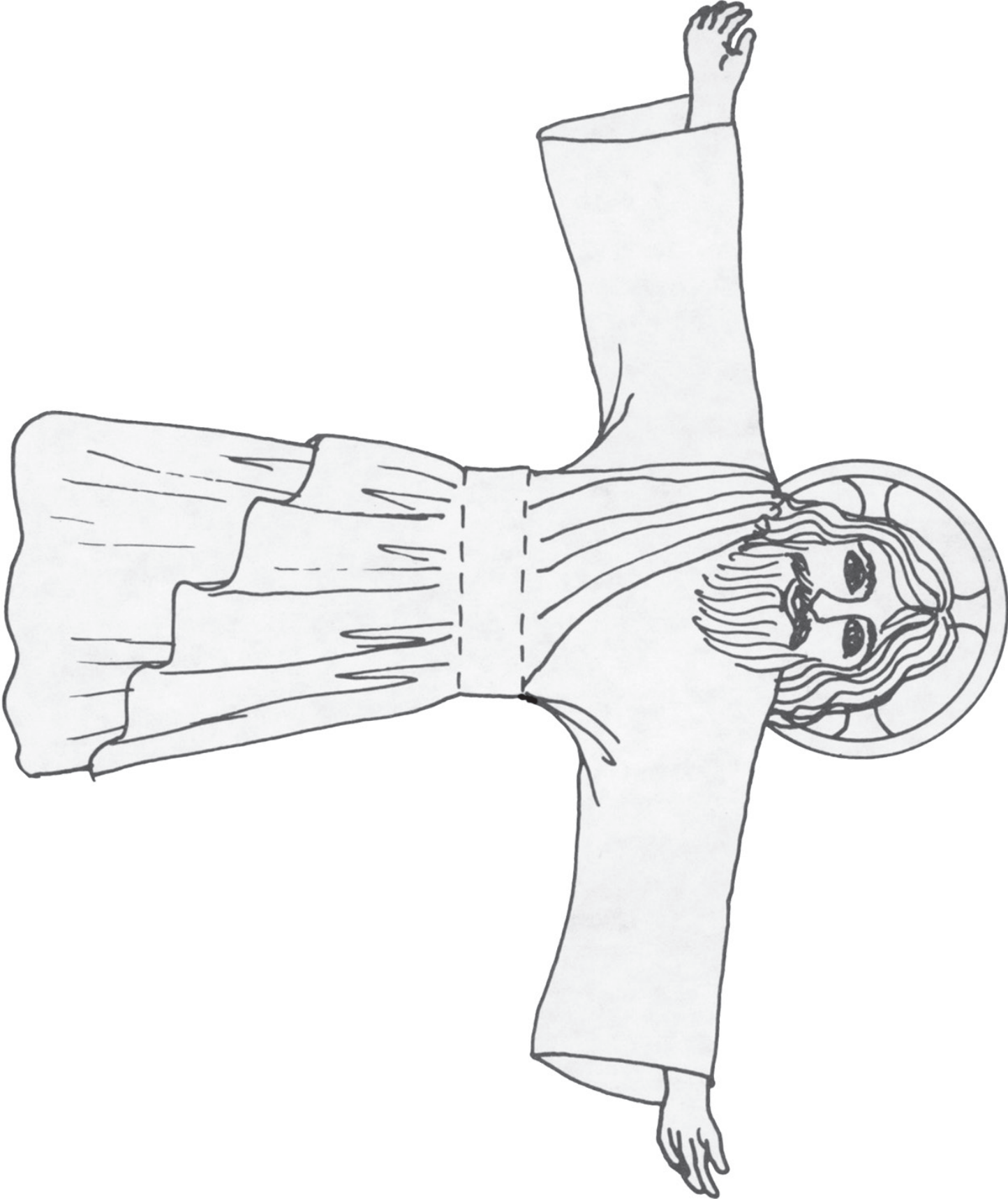



Department of Youth and Education
Diocese of the Armenian Church of America (Eastern)
630 Second Avenue, New York, NY 10016
212 686-0710 www.armenianchurch.net